



TURBO s.r.l.

Electronic Control Systems For Dust Collectors
e-mail: info@turbocontrols.it web: www.turbocontrols.eu
TEL. ++39 (0)362 574024 FAX ++39 (0)362 574092

SEQUENCER

E1T

20 ÷ 24 OUTPUTS



User Manual

General Description

Sequencer for controlling the pneumatic cleaning function of industrial dust collection systems. The device has three output relays contacts and two digital input contacts.

A large, bright display is provided for reading the filter obstruction level, the active solenoid valves and any alarms in any moment.

Technical Specifications

Casing

- Made of insulating, ABS base and polycarbonate lid.
- Degree of protection to water and dust: IP65 (EN60529).
- Shock resistance: IK07, impact energy 2 Joule (EN62262).

Performance of the Device

- LED display with 7 segments, 3 digits (0.8" each).
- Power voltage 115-230 Vac 50-60 Hz selectable by means of jumpers.
- Output voltage 24Vdc, 24-115-230Vac selectable by means of jumper, must also set with F05.
- Three alarm relays, normally closed.
- Micro SD memory card for data storage, extractable for consultation. Sampling is performed every 10 seconds, the time interval is editable.
- Compressed air presence enable input.
- External contact cleaning activation.
- Manual solenoid valve activation.
- Operating times expressed in seconds with selectable ranges for any application.
- Solenoid valve not working alarm.
- Total and partial hour counter for maintenance.
- Setting the current date and time associated with the archiving historical data on the SD card, where are stored the detected values.

Electric Specifications

Electric Power

- ✧ 115 Vac \pm 10% 50-60 Hz – 25W
- ✧ 230 Vac \pm 10% 50-60 Hz – 25W
- ✧ 24 Vac \pm 10% 50-60 Hz – 25W optional
- ✧ 24 Vdc \pm 10% 25W optional

Warning! Read the section on installation before connecting the device.



Selectable Output Voltage

- ✧ 230 Vac
- ✧ 115 Vac
- ✧ 24 Vac
- ✧ 24 Vdc

Inputs And Outputs Galvanically Insulated

- ✧ Enable contact (remote cleaning enable).
- ✧ Fan contact (post-cleaning).

The solenoid valves connected to the unit are normally closed.

The activation of a solenoid valves causes them to open and consequently let out a jet of air.

Alarm Relays

The three alarm relays contain 2 clean contacts on terminals 1 ÷ 6 di J4.

Maximum permitted load: 3A @ 250Vac, 2A @ 24Vac, 2A @ 24Vdc.

The relays are normally closed, opens in case of alarm, and opens to the control unit off in the absence of power.

Fuse

1 x 1 A @ 115Vac. 1 x 1 A @ 230Vac.
1 x 3 A @ 24Vac. 1 x 3 A @ 24Vdc.

Working Temperature

from -10°C to 55°C

Storage Temperature

-20°C to 60°C

Timer Specifications:

Pulse Time (Valve Opening)



from 50 ms to 5 sec

Pause Time (Interval Between Valve Openings)



1 sec - 999 sec

Warning Symbols Used In This Manual

The information regarding safety are highlighted using the symbols:

	Warning-Danger	Generic - Warning-
	Risk - Danger	Electric Current
	Dispose according to the standards for electrical and electronic equipment RAAE	

Installation Rules Notes and Warnings

- ⇒ Protect the device from direct exposure to sunlight.
- ⇒ Do not position the device near or directly in contact with sources of heat or electromagnetic fields. 
- ⇒ Fix the device of a height of at least 60 cm from the ground.
In a clearly visible place easily accessible.
- ⇒ Connect the device to power lines other than those for operating motors or other large power devices which could generate network interference or instability.
- ⇒ The electrical supply of the unit must be protected by a differential switch 230Vac~ 30mA and a bipolar magneto thermic 230Vac~ 10A, positioned in a place easily accessible.
- ⇒ Before working on the equipment to perform any operation switch off the magneto thermic differential switch. 
- ⇒ For electric operations, always remove voltage, wait 30 seconds for the inside capacitors to discharge before opening. At the end of the operations, close the device to restore the correct degree of protection before powering up.
- ⇒ For the connection of the supply voltage, use anti-flame wires with a minimum section of 0.75mm² certified and conform to the standard IEC60227 or IEC60245.
- ⇒ Use flame-retardant cables with a minimum cross-section area of 0.75 mm² for all control signals.
- ⇒ Use flame-retardant cables with a minimum cross-section area of 0.75 mm² to connect to the indicating relays.
- ⇒ Use flame-retardant cables with a minimum cross-section area of 0.5 mm² for electro valves control signals.
- ⇒ The wire ground conductor of protection must be yellow/green.
- ⇒ The wire ground conductor of protection must be connected first.
- ⇒ The wire which is colored yellow/green must only be used for the ground conductor.

- ⇒ The cable glands must be chosen according to the diameter of the cable to be used.
- ⇒ The sealing of the press cable is guaranteed by the compression of the rubber gasket that tightens on the outer diameter of the cable.
- ⇒ The tightness of the cable gland is guaranteed by the compression of the rubber seal that tightens on the outer diameter of the cable.
- ⇒ The size of cable and cable gland must ensure that a power cord traction is not acting on the terminals.
- ⇒ The terminal block must not be the point of mechanical anchoring of the conductors.
- ⇒ The cable gland PG9 supplied on request, has cable diameter minimum of 4mm and a maximum of 8mm, with clamping nut by 19mm.
- ⇒ Any use not described in this user instruction manual or incorrect use of the device may cause damage to the device or to the devices connected to it.
- ⇒ Furthermore, incorrect use or tampering with the device may cause injury.
- ⇒ Waterproofness of the casing is guaranteed when the flap is closed.
- ⇒ Make sure that rigid or flexible ducts used for wiring, if any, do not fill up with water or other liquids.
- ⇒ Do not make holes not protected on the container or protected by accessories with protection degree lower than that of the housing of the control unit.
- ⇒ Cut off power supply immediately if water is found in the casing.
- ⇒ If the control unit is used in ways not specified by the manufacturer, the protection provided by the device may be impaired.
- ⇒ The Control Unit does not release potentially toxic or harmful substances to the health and the environment.
- ⇒ No part with dangerous voltage is normally accessible.

Do not use the control unit if you have not read or do not understand this manual.

Display Keypad

There are four round buttons on the front panel for controlling the device and turning on the display as shown in the following figure.

- The SET button enables to enter and exit the programming menu, and activate the manual solenoid test by selecting function F06.
- The + and - buttons enable to scroll functions from F01 to Fxx. After entering one of the Fxx functions use the OK button to select and then + and - increase or decrease the values.
- The OK button is used to confirm data and reset alarms.
- If the + button is pressed during ordinary operation, the activity hour meter is displayed.
- The - Button pressed during the ordinary operation, displays the counts partial hours of activity.
- If the Micro SD Card is inserted, the pressing of the OK button enables safe removal of the card.



How To Access Programming

- Press SET, the letter F flashes.
- Press + and - to select the required function.
- Press OK to confirm.
- Increase or decrease the value of the parameter press + and -.
- Holding down the + and - buttons to scroll through all the functions until the end of the left or right.
- Press OK to confirm and exit.
- Press SET again to exit programming mode.



List of Functions

- **F02:** Solenoid activation time.
Possible values: 0.05” – 5.00” step 0.01”.
Default = 0.20”.
- **F03:** Washing pause time between solenoid valves.
Possible values: 001” – 999” step 1”.
Default = 20”.
- **F04:** Number of connected outputs.
Possible values: 01 – 24 step 1.
Depending on the version of the instrument, step 1.
- **F05:** Output voltage setting.
Possible values: d24, A24, 115, 230.
Default = A24.
- **F06:** Manual output activation.
Possible values: 1 – number of outputs set in F04.
Press SET to activate the set output.
- **F13:** Number of post cleaning cycles after stopping the fan.
Possible values: 01 – 99 step 1.
Default = 01.
- **F14:** Post cleaning mode pause time between solenoid valves (fan off).
Possible values: 001” – 999” step 1”.
Default = 10”.
- **F15:** Maintenance frequency expressed in tens of hours.
(e.g.: 1=10h, 10=100h).
Possible values: 001 – 999 step 1.
Default = 100 (=1000h).
- **F16:** Maintenance deadline alarm enable.
Possible values: 0 (disabled) – 1 (enabled).
Default = 0 (disabled).
- **F17:** Maintenance hour counter reset.
Possible values: 0 (disabled) – 1 (reset).
Default = 0 (disabled).
Note: The maintenance hour counter will be reset and the F17 parameter will be set back to 0 by setting F17 to 1.
- **F24:** Setting the date on the internal clock.
Settable values: Day 1 – 31 *d*.
Month 1 – 12 *m*.
Year 00 – 99 *y*.
- **F25:** Setting of the time for the internal clock.
Settable values: Hours: 0 – 23 *HH*.
Minutes: 0 – 59 *mm*.
- **F26:** Exclusion of the valve in short circuit.
If set to 1 the valve shorted is excluded from the cycle.
Settable Values 0 (not excluded) - 1 (excluding)
Default = 0 (not excluded).

Alarms

The unit runs a number of checks during the start-up cycle and during normal operation. The possible alarms and respective solutions are shown in the following table.

A. No.	Description	Action
E01	F05 set to 24 Vdc AC jumper detected	- For 24Vdc, switch the device off and move the AC/DC jumpers to DC. - For 24Vac, press OK, then press SET, set the function F05 using "+" and "-", select A24 and press OK to confirm.
E02	F05 set to 24 Vac DC jumper detected	- For 24Vac, switch the device off and move the AC/DC jumpers to AC. - For 24Vdc, press OK, then press SET, set the function F05 using "+" and "-", select d24 and press OK to confirm.
E03	F05 set to 24 Vac or Vdc. Voltage out of range detected	- To use 24V valves, switch the device off and move the output voltage selection jumper to 24V. If the jumper is in the correct position, press OK, then SET, select the F05 function with "+" and "-", set 115 or 230 (as jumper) and press OK.
E04	F05 set to 115 Vac. Voltage out of range detected	- To use 115V valves, switch the device off and move the output voltage selection jumper to 115V. If the jumper is in the correct position, press OK, then SET, select the F05 function with "+" and "-", set 115 or 230 (as jumper) and press OK.
E05	F05 set to 230 Vac. Voltage out of range detected	- To use 230V valves, switch the device off and move the output voltage selection jumper to 230V. - If the jumper is in the correct position, press OK, then SET, select the F05 function with "+" and "-", set a24, d24 or 115 (as jumper) and press OK.
E06	Solenoid valve current lower than minimum threshold or disconnected solenoid valve	Check correct connection of the solenoid valve and respective data. The alarm is self-reset.
E07	Solenoid valve current higher than maximum threshold	Check correct connection of the solenoid valve and respective data. The alarm is self-reset.
E08	Output short circuit The signaling of the code E08 alternates with the indication of the interested output is shown as Uxx where xx is the number of the output.	Turn off the device and then turn it back on, after having verified the plant of the solenoid valves.

E11	Maintenance deadline reached	Carry out maintenance.
E14	<p>Indicates that a valve in short circuit has been excluded from the cycle.</p> <p>The signaling of the code E14 alternates with the indication of the interested output, is shown as Uxx where xx is the number of the output.</p> <p>An output is considered a short circuit if not responding for 3 following activations.</p> <p>An activation without error resets the counting.</p>	Turn off the device and then turn it back on, after having verified the plant of the solenoid valves.
E20	Internal clock error.	Replace buffer battery (CR1632 3V 130mAh) and set current time and date.

Description Of Operation

The installed SW version and the symbol ---, meaning that coherence between settings stored in E2Prom and the set jumpers is being checked, will appear on the display when the sequencer is powered up. A corresponding error code will appear in case of discrepancies between settings (see Alarms Table). Only editing functions will be allowed on the unit. The operator may switch off the unit and configure the jumpers correctly.

Symbol 0_0 will appear on the display if the test is entirely successful. The following pages will then appear:

OFF if the enabling contact is open (14-15).

-0- if the enabling contact (14-15) is closed and the fan is off.

Operative mode

The device works as a programmable cycle sequencer. The connected outputs will be activated at the programmable frequencies. The firing and pausing times can be set on the configuration menu.

Cleaning Function With Fan Off (PCC)

This function allows to carry out one or more cleaning cycles (the number of cycles is defined by F13) when the fan is off. The on or off state of the fan may be determined by the state of the contacts 12-13 (contacts open = fan off) if F11=0, or may be determined automatically (with F11=1) when the dP pressure drops under the threshold defined in F12. The pulse time of the valves will always be that defined in F02, while the pause time in this case is defined in F14.

The display alternately shows the number of the valve activated and the word CCP.

Number Of Output Selection

The number of outputs (solenoid valves) on which the sequencer will run the cleaning cycle can be selected. Cleaning will be carried out in order from the first to the last solenoid valve. The valves can be adjusted by the F04 function.

Fuse

A fuse which can be reset in case of need is located near the power terminal board. Use a delayed fuse 5x20mm as shown in the table on next pages.

SD Memory Card

The Micro SD memory card slot is located on the bottom right of the control unit under the polycarbonate lid.

The card is not supplied with the control unit. A card with a maximum of 32GB can be used.

The card must be formatted FAT32, which is the format recognized by all devices and operating systems.

Before removing the memory card, press the OK button with the control unit on, wait for the cd (card) indication and the alternating flashing of the horizontal lines of the third figure ≡. The card can now be safely removed. The Micro SD Card connector is push-pull.

Press upwards and extract the card to remove it.

Connection Diagram Main Board

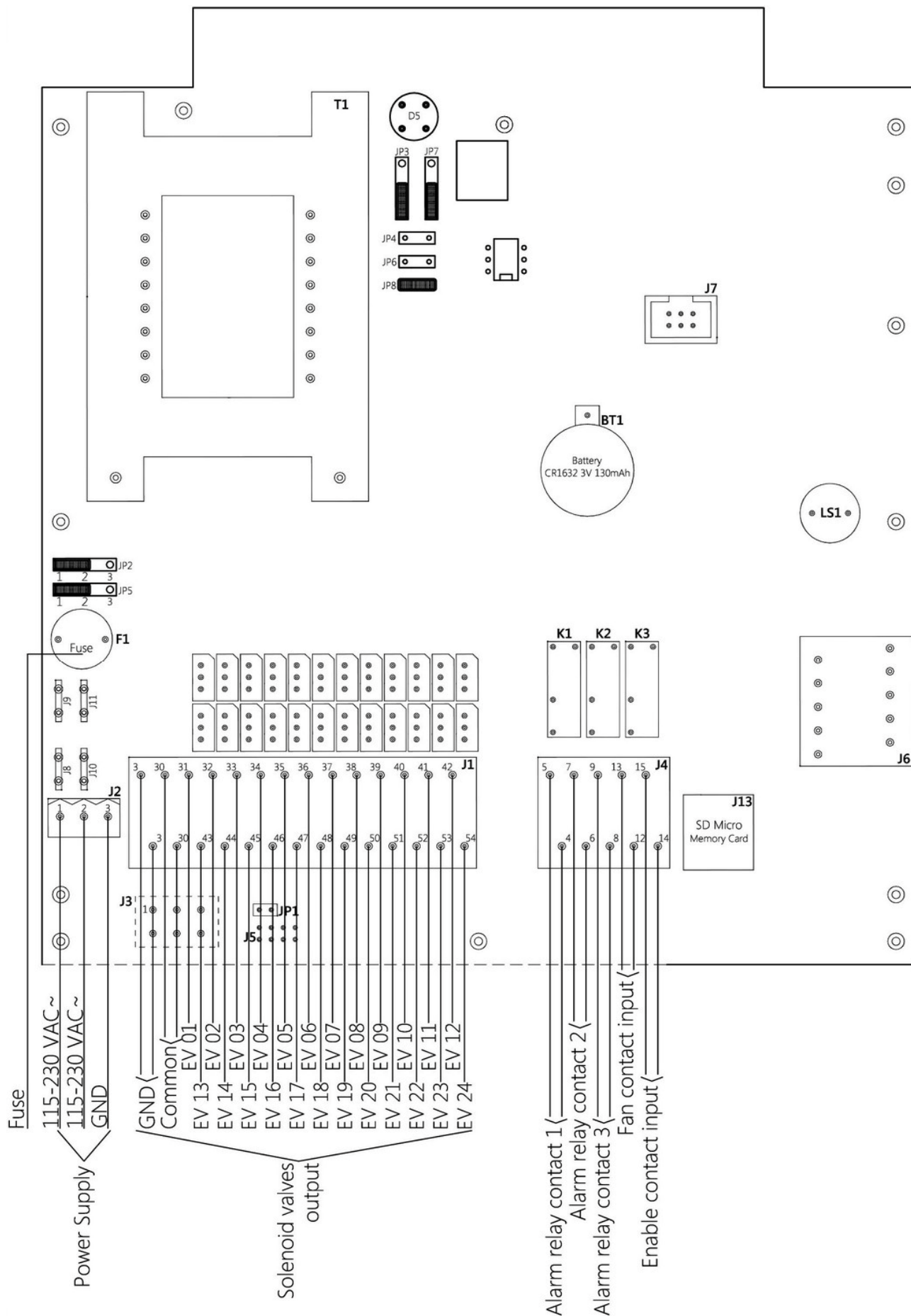

Contacts And Relay Terminal Block J4

Enable contact input consensus 14.15 terminals.

Is used to activate the control unit remotely, it can be turned on and off remotely.

The unit is supplied with a jumper on the two terminals 14:15, without it will not turn on.

Fan contact 12.13 input terminals.

Indicated by the control unit that the plant has been started and is in operation.

The unit is supplied with a jumper on two 12:13 terminals to simulate the state of the plant, as if the fan was turned on.

Alarm Relay K1 4.5 terminals.

The relay is normally closed, opens in case of alarms, and opens to the control unit off in the absence of power.

The alarms that open the relays are:

Problem with solenoid valves E06-E08.

Maintenance interval has been reached.

If one of these occurs, the relay is activated.

Terminal Table

To access at the terminal blocks of the control board, unscrewing countersunk screws of the cover panel.

Main Board			
Terminal	Description	Terminal	Description
01	Power Supply 115 230 Vac	46	Solenoid output 16
02	Power Supply 115 230 Vac	47	Solenoid output 17
03	Earth Gnd	48	Solenoid output 18
		49	Solenoid output 19
03	Earth Gnd Solenoid valves	50	Solenoid output 20
30	Solenoid valve common	51	Solenoid output 21
31	Solenoid output 01	52	Solenoid output 22
32	Solenoid output 02	53	Solenoid output 23
33	Solenoid output 03	54	Solenoid output 24
34	Solenoid output 04		
35	Solenoid output 05	04	Alarm relay contact 01
36	Solenoid output 06	05	Alarm relay contact 01
37	Solenoid output 07	06	Alarm relay contact 02
38	Solenoid output 08	07	Alarm relay contact 02
39	Solenoid output 09	08	Alarm relay contact 03
40	Solenoid output 10	09	Alarm relay contact 03
41	Solenoid output 11	12	Fan input
42	Solenoid output 12	13	Fan input
43	Solenoid output 13	14	Enable input
44	Solenoid output 14	15	Enable input
45	Solenoid output 15		

If the sequencer is in G2 version with reinforced transformer, connect two solenoid valves in parallel to each terminal.

Fuse Table

Voltage	Value
230 V	1 A
115 V	1 A
24 Vdc / Vac	3 A

Jumper Configuration Power Supply

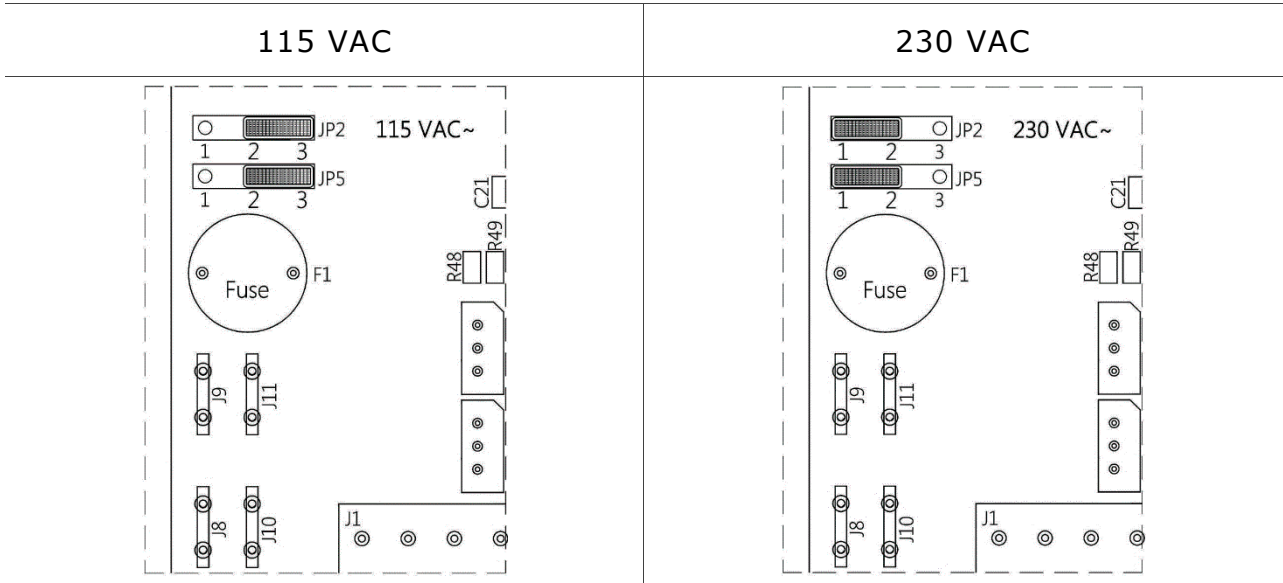

Jumper Configuration Output

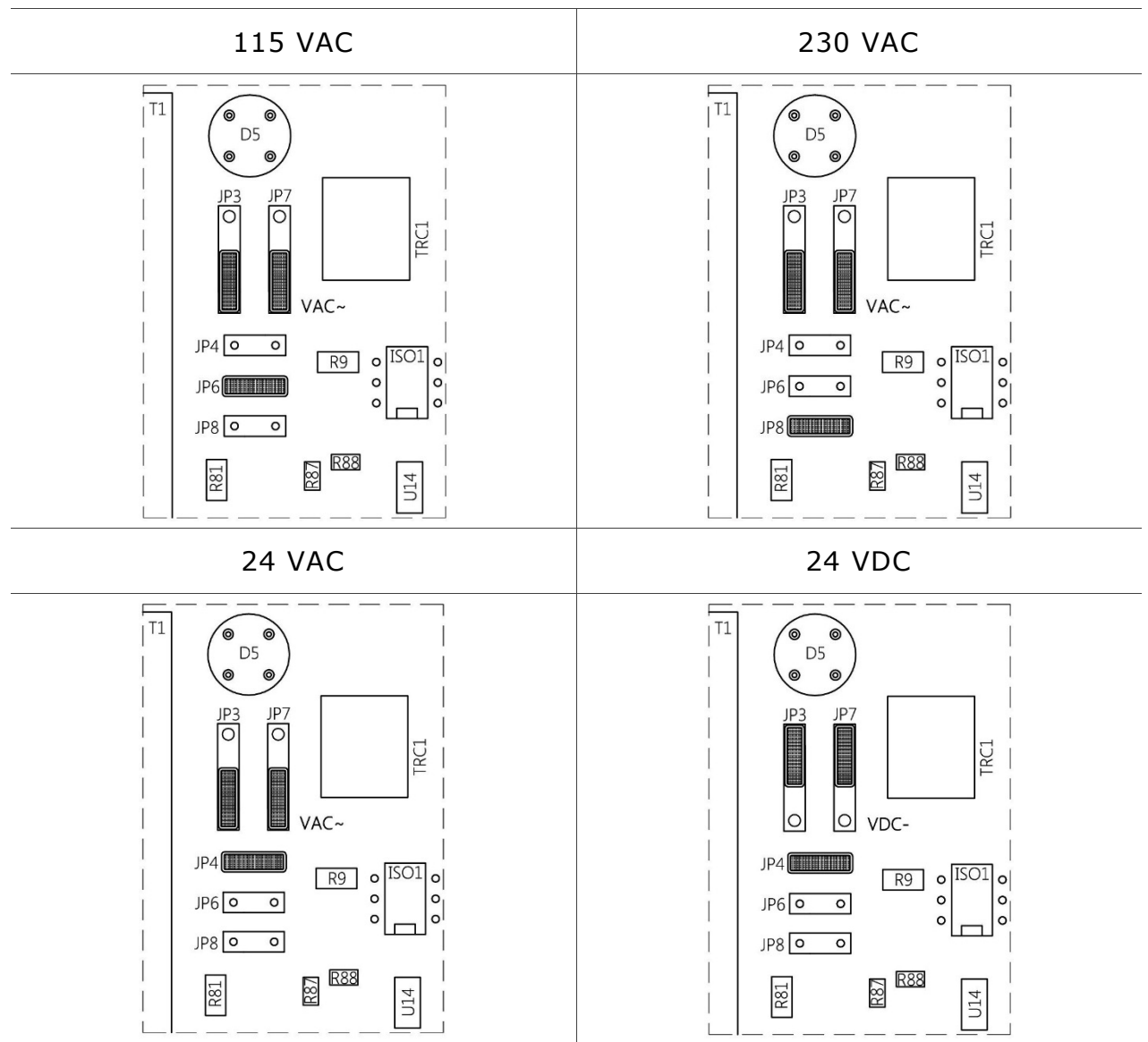

Installation And Casing Dimensions

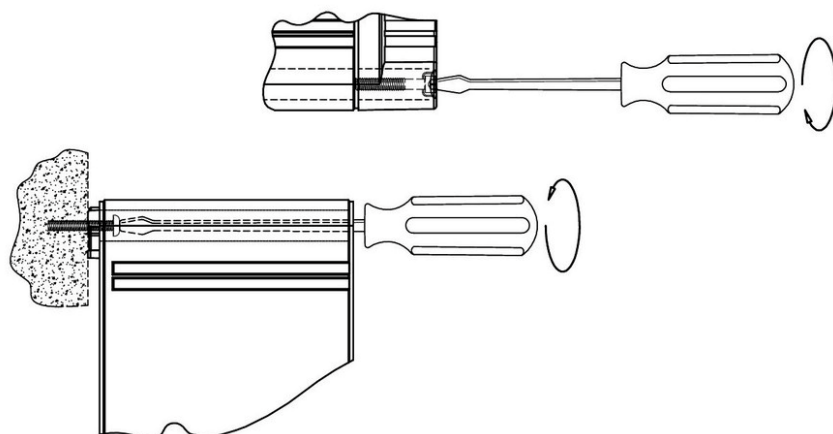
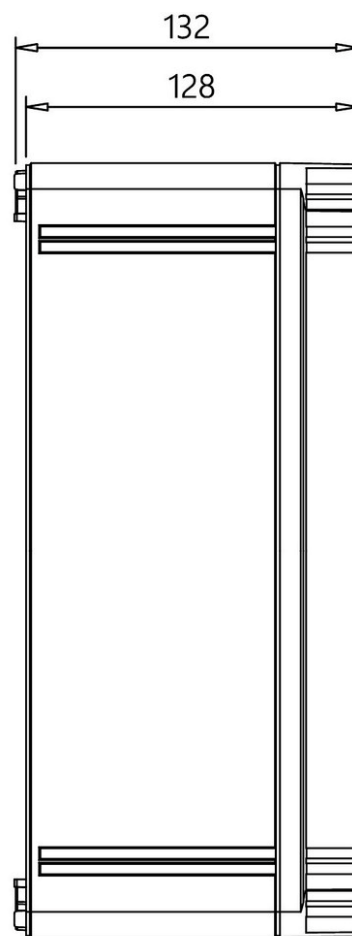
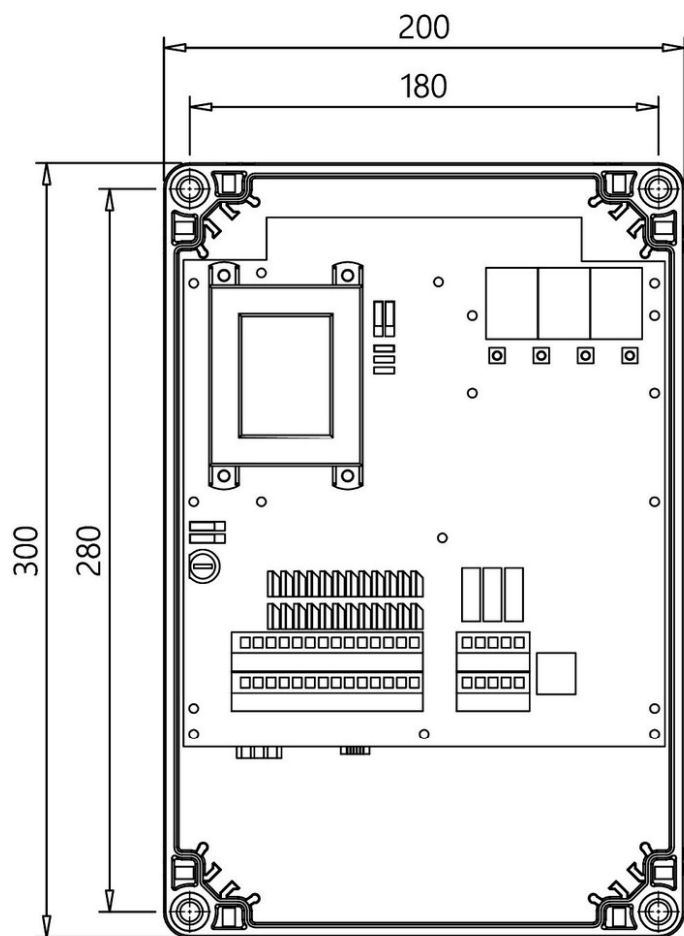

Weight 2.4 Kg

Maintenance

Only the fuses, batteries and SD card can be replaced.
All other repairs must be done by the manufacturer.

Default Settings

Function Number	Description	Set Value
F02	Solenoid valve activation time	0.20 Sec.
F03	Washing pause time between solenoid valves in normal cycle	020 Sec.
F04	Number of outputs	1
F05	Output voltage: 24 Vdc, 24 Vac, 115 Vac, 230 Vac.	24 Vac
F06	Manual solenoid valve activation	1
F13	Number of cycles after fan stop	1
F14	Pause time between solenoid valves in cycle with fan off	10 Sec.
F15	Maintenance frequency in 10h (1=10h, 100=1000h)	100
F16	Maintenance deadline alarm on (1) or off (0)	0
F17	Maintenance hour counter reset: set 1 and confirm to reset the maintenance hour counter	0
F26	Exclusion of valve in short circuit.	0

Disposal

Do not disperse in the environment after use. Dispose of the product according to current regulations for the disposal of electronic equipment.



This device is used in a dust collector system and, therefore, it is part of a fixed installation.

Warranty

The warranty has a duration of 2 years. The company will replace any electronic component deemed defective exclusively at our workshop, except in the presence of contrary agreements to be authorized by the company.

Exclusions From Warranty

The warranty is void in the case of:

- Signs of tampering and unauthorised repairs.
- Incorrect use of the equipment that does not comply with the technical data.
- Incorrect electrical connections.
- Failure to comply with the installation standards.
- Use beyond EC standards.
- Atmospheric events (lightning, electrostatic discharge), over voltages.
- Clogged air connections. Damaged tubes.

Problem Solution FAQ

Fault	Possible Cause	Solution
The display does not light up.	Burnt fuse.	Check the protection fuse on the power voltage. Check that the power voltage is present and compliant with that required for the device (terminals 01 and 03).
The outputs are not activated.	Incorrect output voltage. Wiring to solenoid valves.	Check that the unit and solenoid valve output voltage agree. Check wiring between sequencer and solenoid valves.
Do alarm messages appear?		Check the alarm code with the table.
Do the alarms fail to activate signalling devices?	System wiring errors. No power to alarm devices.	The alarm devices must be powered by voltage external to the sequencer. Activating to open the respective relay.
Does the sequencer occasionally reset?	Check the there is no filtered pulse load on the power line (spot welding machines, welding machines, plasma cutters etc.).	Install a filter on the power line of the sequencer, if needed.



Declaration Of Conformity Of The Manufacturer

The Manufacturer:

TURBO SRL

The Manufacturer's Address:

Via Po 33/35 20811 Cesano Maderno (MB), Italy

Declares that:

Product Name:

Sequencer E1T

Product Options:

All

Complies with the following directives:

Directive 2014/30/EU Electromagnetic Compatibility compliant with Harmonised European standards EN61000-6-2:2005 class B of EN61000-6-4:2001

Directive 2014/35/EU Low Voltage compliant with Harmonised European Standards EN 60947-1:2004

A typical configuration of the product was tested.

Cesano Maderno, 05/01/2016

F. MESSINA (C.E.O.)

TURBO s.r.l.

Code And Serial Number