

REMOTE PILOT FOR DIAPHRAGM VALVES- ESRM SERIES

LONG-DISTANCE ACTIVATION



FEATURES

Fluids	Non-lubricated filtered air
Operating pressure	between 0.5 and 7.5 bar
Operating temperature	-20°C; +80°C
Body	Brass
Pilot core	Stainless steel
Coil insulation	Class H
Connector	PG9 / IP 65
Standard voltage	24VDC (12W)

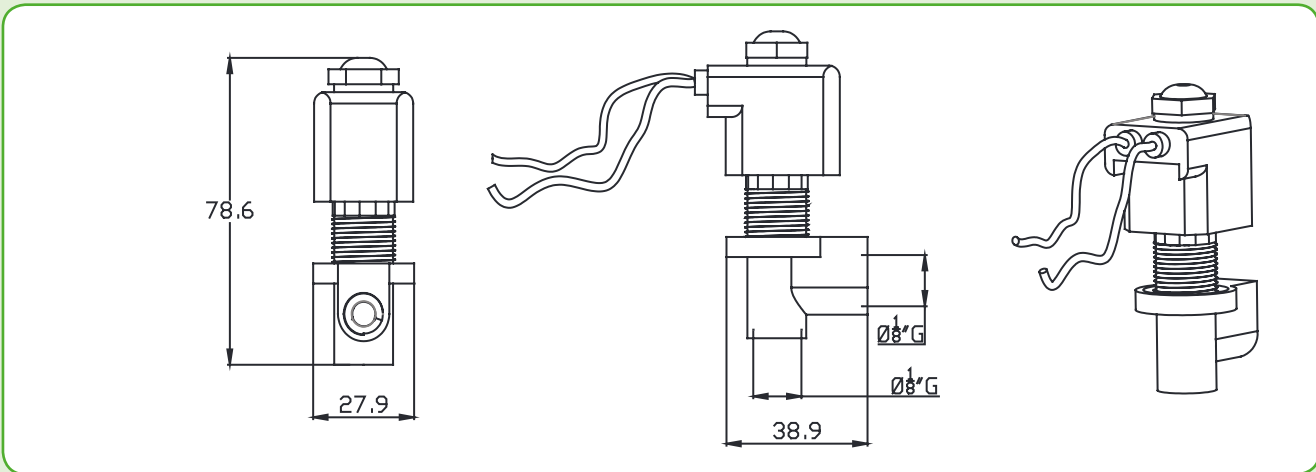

ESRM

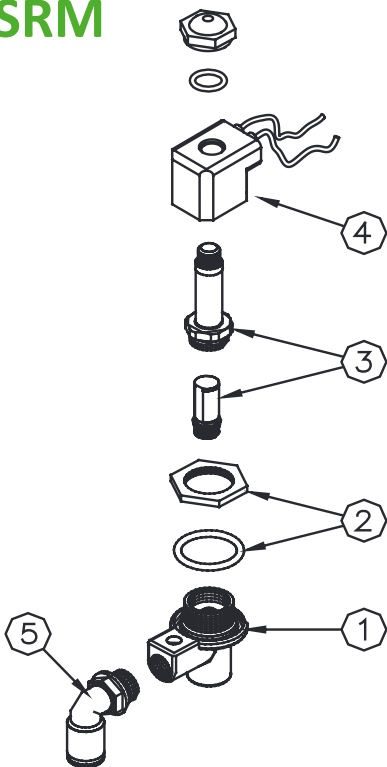

DESCRIPTION

DESCRIPTION	ESRM
1 Pilot body	PCR P
2 Second lock nut + O-ring	3121604 - 3301224
3 Pilot unit	1331088
4 Coil	4121048
5 Quick connection elbow for 6x4 rislan pipe	3421002