

XTF SERIES DN 5" - 6" - 8" - 10" - WITH THREADED STUMPS

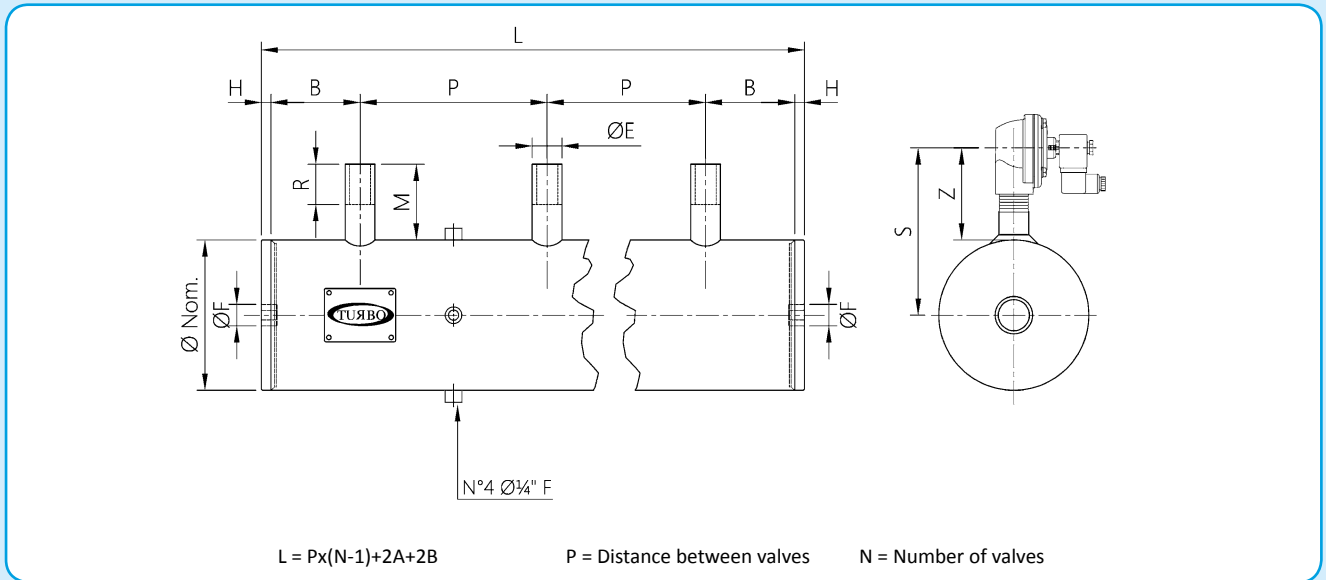

For special versions of P min and B min, please contact our technical department

Ø (NOM)	Ø(out) mm	ØE	B(min)	ØF	H	M	R	Z(±)	S(±)	P(min)
5"	140	¾"	40	1"	10	85	40	120	190	85
5"	140	1"	45	1"	10	85	40	120	190	85
5"	140	1 ½"	50	1"	10	85	40	120	205	150
6"	168.3	¾"	40	1"	10	85	40	120	204	85
6"	168.3	1"	45	1"	10	85	40	120	204	85
6"	168.3	1 ½"	55	1"	10	85	40	136	220	150
6"	168.3	2"	60	1"	10	75	40	164	248	210
8"	219.1	1"	45	1 ½"	10	85	40	120	229	85
8"	219.1	1 ½"	55	1 ½"	10	85	40	136	245	150
8"	219.1	2"	60	1 ½"	10	75	40	164	273	210
8"	219.1	2 ½"	65	1 ½"	10	85	40	164	273	210
10"	273	1 ½"	55	1 ½"	12	85	40	136	272	150
10"	273	2"	60	1 ½"	12	75	40	164	300	210
10"	273	2 ½"	70	1 ½"	12	70	45	164	300	210

Operating temperature: -50°C/+200°C

5" - 6" - 8" - 10" DN INX INTEGRAL SERIES - GLOBAL IMMERSION HEADER TANKS

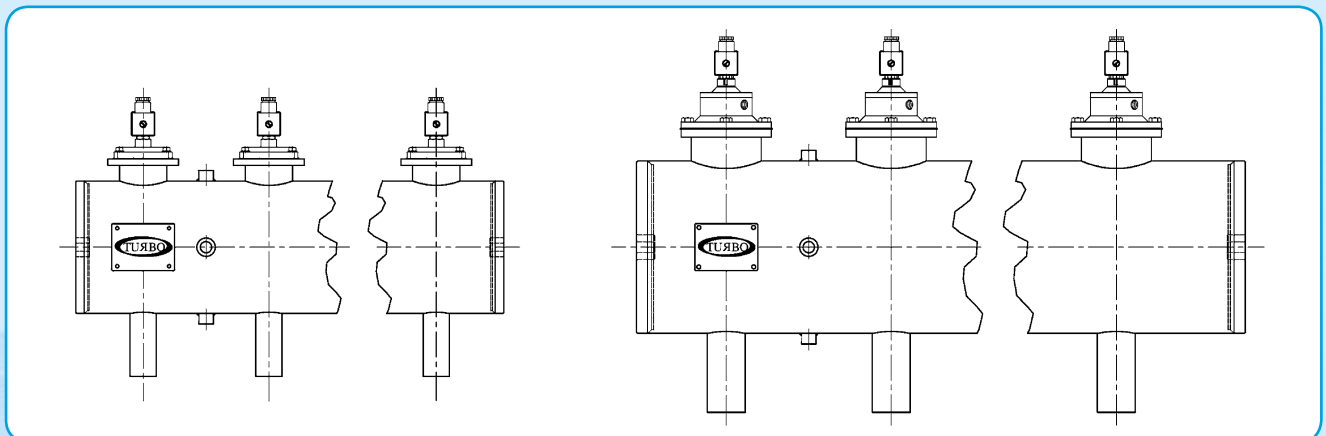

Please contact our technical department for the dimensions
 Operating temperature: -50°C/+200°C