

E8T CONTROL UNIT ECONOMISER 4÷16 OUTPUT CHANNELS



DESCRIPTION

Economiser for controlling the pneumatic cleaning of industrial dust collector systems. It has 3 output relay contacts and 2 digital input contacts.

Differential pressure digital control through internal transducer, which allows the accurate analysis of the filter clogging status.

Luminous LCD screen, which allows to read the following at all times

- the operating status of the unit
- the filter clogging status dP value
- the solenoid valves active and any alarms
- time until the command of the next air jet
- the emission value

Interface menu available in five languages.

OPTIONS UPON REQUEST

- Activation of 2 solenoid valves for every output channel.
- Analogue electrical tribo sensor management
- Cable glands for power supply input and output of solenoid valves drive cables.
- Connector from wired panel for connection to Matrix cabling.
- Zone 22 ATEX Certification.

REFERENCE STANDARDS

- Directive 2014/30/EC Electromagnetic Compatibility meeting European harmonised standards EN61000-6-2:2005 class B in standard EN61000-6-4:2001
- Directive 2014/35/EU Low Voltage meeting European harmonised standards EN 60947-1:2004

TECHNICAL SPECIFICATIONS

| | |
|---|--|
| Power supply voltage | 115 Vac 50-60 Hz \pm 10 % 230 Vac 50-60 Hz \pm 10 % |
| Power supply voltage | 24 Vac \pm 10 % |
| Alternative upon request | 24 Vdc \pm 10 % |
| Output voltage for solenoid valves | 115 Vac 50-60 Hz 230 Vac 50-60 Hz 24 Vac 24 Vdc |
| Inputs | from 4 to 20mA x 1 |
| Outputs proportionate to dP value for remote pressure reading | from 4 to 20mA x 1 |
| Solenoid valves output channels | 01 ÷ 16 |
| Electric consumption | 28 Watts at maximum load |
| Alarm Relays | 3 normally closed Maximum load: 3A @ 250Vac, 2A @ 24Vdc, 24 Vac. |
| Screen | Backlit monochromatic graphic LCD B/N 128 x 64 pixel |
| 5 x 20 mm glass fuse | 115 or 230 Vac 1 x 1 A 24 Vac or 24 Vdc 1 x 3 A |
| Operating temperature | -10 °C - 55 °C |
| Storage temperature | -20 °C - 60 °C |
| Environmental humidity | 0 ÷ 95% Relative non condensing |
| Valves opening impulse time | 50 m.sec. ÷ 10 sec. |
| Interval pause time between valves opening | 1 sec. ÷ 7200 sec. |
| Measurable pressure | 0 - 10 kPa |
| Casing | Base in ABS Lid in Polycarbonate |
| Protection rating from water and dust | IP65 DIN EN 60529 |
| Shock resistance | IK07 2 Joule (EN62262) |

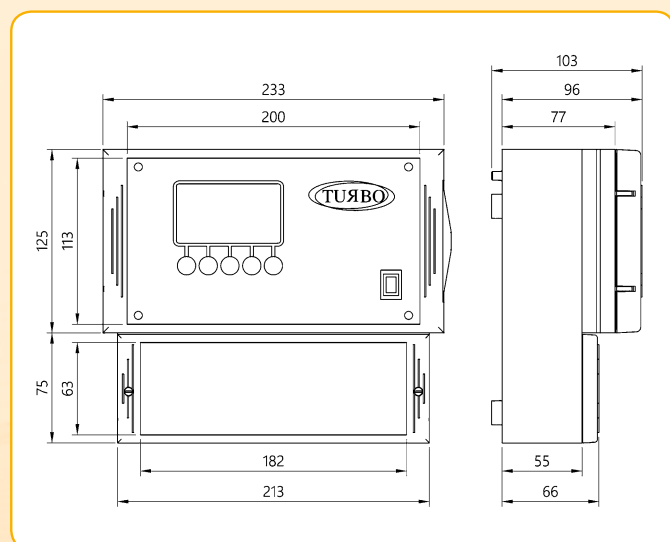

For additional information and technical specifications, consult www.turbocontrols.eu