



TURBO s.r.l.
Electronic Control Systems for Dust Collectors
e-mail: info@turbocontrols.it
web: www.turbocontrols.eu
TEL. ++39 (0)362 574024 FAX ++39 (0)362 574092

SEQUENCER SERIES E1T USER MANUAL 12 Vdc



General Description

Sequencer for controlling the pneumatic cleaning function of industrial dust collection systems. The device has two output relays contacts and two digital input contacts. A large, bright display is provided for reading the timer operation, the active solenoid valves and any alarms in any moment.

Technical Specifications

Casing

- Made of insulating, ABS base and polycarbonate lid.
- Degree of protection to water and dust: IP65 (EN60529).
- Shock resistance: IK07 2 Joule (EN62262).

Performance of the Device

- LED display with 7 segments, 3 digits 0.8" each.
- Operating times expressed in seconds with selectable ranges for any application.
- Power supplier 12 Vdc.
- Output voltage 12 Vdc selectable by means of jumper, must also set with F05.
- Fan off washing function (post-cleaning) by means of contact with selectable number of cycles up to 99.
- Total and partial hour counter for maintenance.
- Two alarm relays, normally closed.
- Solenoid valve not working alarm.
- External contact cleaning activation.
- Compressed air presence enable input.
- Manual solenoid valve activation.

Electric Specifications

Electric Power:

- 12 Vdc \pm 10% 25W



Important: Read the installation instruction section before connecting the device.

Selectable Output Voltage:

- 12 Vdc

Inputs And Outputs Not Galvanically Insulated:

- Enable contact (remote cleaning enable).
- Fan contact (post-cleaning).

The solenoid valves connected to the unit are normally closed.

The activation of a solenoid valves causes them to open and consequently let out a jet of air.

Alarm Relays:

The alarm relays has two voltage-free contacts on terminals 4-5 (Relay 1) and 6-7 (relay 2).

Maximum permitted load: 2A @ 12 Vdc

The relays are normally closed, opens in case of alarms, and opens with the control unit off or in the absence of power.

Fuse

1 x 3 A @ 12 Vdc.

Working Temperature:

from -10°C to 55°C

Storage Temperature:

from -20°C to 60°C

Timer Specifications:

Pulse Time (Valve Opening)



from 50 msec. to 5 sec.

Pause Time (Interval Between Valve Openings)



1 sec - 999 sec.

Warning Symbols Used In This Manual

The information regarding safety are highlighted using the symbols:

	Warning-Danger	Generic - Warning-
	Risk - Danger	Electric Current
	Dispose according to the standards for electrical and electronic equipment RAAE	

Installation Rules Notes and Warnings

- ⦿ Protect the device from direct exposure to sunlight.
- ⦿ Do not position the device near or directly in contact with sources of heat or electromagnetic fields. 
- ⦿ Fix the device of a height of at least 60 cm from the ground.
In a clearly visible place easily accessible.
- ⦿ Connect the device to power lines other than those for operating motors or other large power devices which could generate network interference or instability.
- ⦿ The electrical supply of the unit must be protected by a differential switch 230Vac~ 30mA and a bipolar magneto thermic 230Vac~ 10A, positioned in a place easily accessible.
- ⦿ Before working on the equipment to perform any operation switch off the magneto thermic differential switch. 
- ⦿ For electric operations, always remove voltage, wait 30 seconds for the inside capacitors to discharge before opening. At the end of the operations, close the device to restore the correct degree of protection before powering up.
- ⦿ For the connection of the supply voltage, use anti-flame wires with a minimum section of 0.75mm² certified and conform to the standard IEC60227 or IEC60245.
- ⦿ Use flame-retardant cables with a minimum cross-section area of 0.75 mm² for all control signals.
- ⦿ Use flame-retardant cables with a minimum cross-section area of 0.75 mm² to connect to the indicating relays.
- ⦿ Use flame-retardant cables with a minimum cross-section area of 0.5 mm² for electro valves control signals.
- ⦿ The wire ground conductor of protection must be yellow/green.
- ⦿ The wire ground conductor of protection must be connected first.
- ⦿ The wire which is colored yellow/green must only be used for the ground conductor.

- ⇒ The cable glands must be chosen according to the diameter of the cable to be used.
- ⇒ The sealing of the press cable is guaranteed by the compression of the rubber gasket that tightens on the outer diameter of the cable.
- ⇒ The tightness of the cable gland is guaranteed by the compression of the rubber seal that tightens on the outer diameter of the cable.
- ⇒ The size of cable and cable gland must ensure that a power cord traction is not acting on the terminals.
- ⇒ The terminal block must not be the point of mechanical anchoring of the conductors.
- ⇒ The cable gland PG9 supplied on request, has cable diameter minimum of 4mm and a maximum of 8mm, with clamping nut by 19mm.
- ⇒ Any use not described in this user instruction manual or incorrect use of the device may cause damage to the device or to the devices connected to it.
- ⇒ Furthermore, incorrect use or tampering with the device may cause injury.
- ⇒ Waterproofness of the casing is guaranteed when the flap is closed.
- ⇒ Make sure that rigid or flexible ducts used for wiring, if any, do not fill up with water or other liquids.
- ⇒ Do not make holes not protected on the container or protected by accessories with protection degree lower than that of the housing of the control unit.
- ⇒ Cut off power supply immediately if water is found in the casing.
- ⇒ If the control unit is used in ways not specified by the manufacturer, the protection provided by the device may be impaired.
- ⇒ The Control Unit does not release potentially toxic or harmful substances to the health and the environment.
- ⇒ No part with dangerous voltage is normally accessible.

Do not use the control unit if you have not read or do not understand this manual.

Display / Keypad

There are four round buttons on the front panel for controlling the device on the front panel. The display will appear similar to the following when it is turned on.

- The SET button enables to enter and exit the programming menu, and activate the manual test of solenoid valve selected in function F06.
- The + and - buttons enable to scroll functions from F01 to Fxx. After entering one of the Fxx functions use the OK button to select and then + and - increase or decrease the values.
- The OK button is used to confirm data and reset alarms.
- If the + button is pressed during ordinary operation, the activity hour meter is displayed.
- The - Button pressed during the ordinary operation, displays the counts partial hours of activity.



Menu Diagram

- Press SET, the letter F flashes.
- Press + and - to select the required function.
- Press OK to confirm.
- Increase or decrease the value of the parameter with + and - buttons.
- Holding down the + and - buttons to scroll through all the functions until the end of the left or right.
- Press OK to confirm and exit.
- Press SET again to exit programming mode.



List Of Functions

- **F02:**
Solenoid valve activation time.
Possible values: 0.05" – 5.00" step 0.01".
Default = 0.20".
- **F03:**
Washing pause time between solenoid valves.
Possible values: 001" – 999" step 1".
Default = 020".
- **F04:**
Number of connected outputs.
Possible values: 01 – 16 step 1.
Default = 001.
- **F05:**
Output voltage setting, must agree with jumpers.
Possible values: d12.
Default = d12.
- **F06:**
Manual output activation.
Possible values: 1 – number of outputs set in F04.
Press SET to activate the set output.
- **F13:**
Number of post cleaning cycles after stopping the fan.
Possible values: 01 – 99 step 1.
Default = 01.
- **F14:**
Post cleaning mode pause time (fan off).
Possible values: 001" – 999" step 1".
Default = 010".
- **F15:**
Maintenance frequency expressed in tens of hours (e.g.: 1=10h, 10=100h).
Possible values: 001 – 999 step 1.
Default = 100 (=1000h).
- **F16:**
Maintenance deadline alarm enable.
Possible values: 0 (disabled) – 1 (enabled).
Default = 0 (disabled).
- **F17:**
Maintenance hour counter reset.
Possible values: 0 (disabled) – 1 (reset).
Default = 0 (disabled).
Note: The maintenance hour counter will be reset and the F17 parameter will be set back to 0 by setting F17 to 1.
- **F24**
Exclusion of the valve in short circuit.
If set to 1 the valve shorted is excluded from the cycle.
Settable Values 0 (not excluded) - 1 (excluding)
Default = 0 (not excluded).

Alarms

The unit runs a number of checks during the start-up cycle and during normal operation. The possible alarms and respective solutions are shown in the following table.

Alarm No.	Description	Action
E06	Solenoid valve current lower than minimum threshold or disconnected solenoid valve	Check correct connection of the solenoid valve and respective data. The alarm is self-reset.
E07	Solenoid valve current higher than maximum threshold	Check correct connection of the solenoid valve and respective data. The alarm is self-reset.
E08	Output short circuit. Alarm The signaling of the code E08 alternates with the indication of the interested output is shown as Uxx where xx is the number of the output.	Switch the device off and back on after having checked the solenoid valve system.
E11	Maintenance deadline reached	Carry out maintenance.
E14	Indicates that a valve in short circuit has been excluded from the cycle. The signaling of the code E14 alternates with the indication of the interested output is shown as Uxx where xx is the number of the output. An output is considered a short circuit if not responding for 3 following activations. An activation without error resets the counting.	Switch the device off and back on after having checked the solenoid valve system.

Description Of Operation

The installed SW version and the symbol ---, meaning that coherence between settings stored in E2Prom and the set jumpers is being checked, will appear on the display when the sequencer is powered up. A corresponding error code will appear in case of discrepancies between settings (see Alarms Table). Only editing functions will be allowed on the unit. The operator may switch off the unit and configure the jumpers correctly. Symbol 0_0 will appear on the display if the test is entirely successful.

The following pages will then appear:

- OFF if the enabling contact is open (14-15)
- -0- if the enabling contact (14-15) is closed and the fan is off

Operative Mode

The device works as a programmable cycle sequencer. The connected outputs will be activated at the programmable frequencies. The firing and pausing times can be set on the configuration menu.

Cleaning Function With Fan Off (PCC)

This function allows to carry out one or more cleaning cycles (the number of cycles is defined by F13) when the fan is off. The on or off state of the fan is determined by the state of contacts 12-13 (contacts open = fan off). The pulse time of the valves will always be that defined in F02, while the pause time in this case is defined in F14.

The display alternately shows the number of the valve activated and the word PCC.

Number Of Output Selection

The number of outputs (solenoid valves) on which the sequencer will run the cleaning cycle can be selected. Cleaning will be carried out in order from the first to the last solenoid valve. The valves can be adjusted by the F04 function.

Fuse

A fuse which can be reset in case of need is located near the power terminal board. Use a delayed fuse 5x20 mm.

Connection Diagram

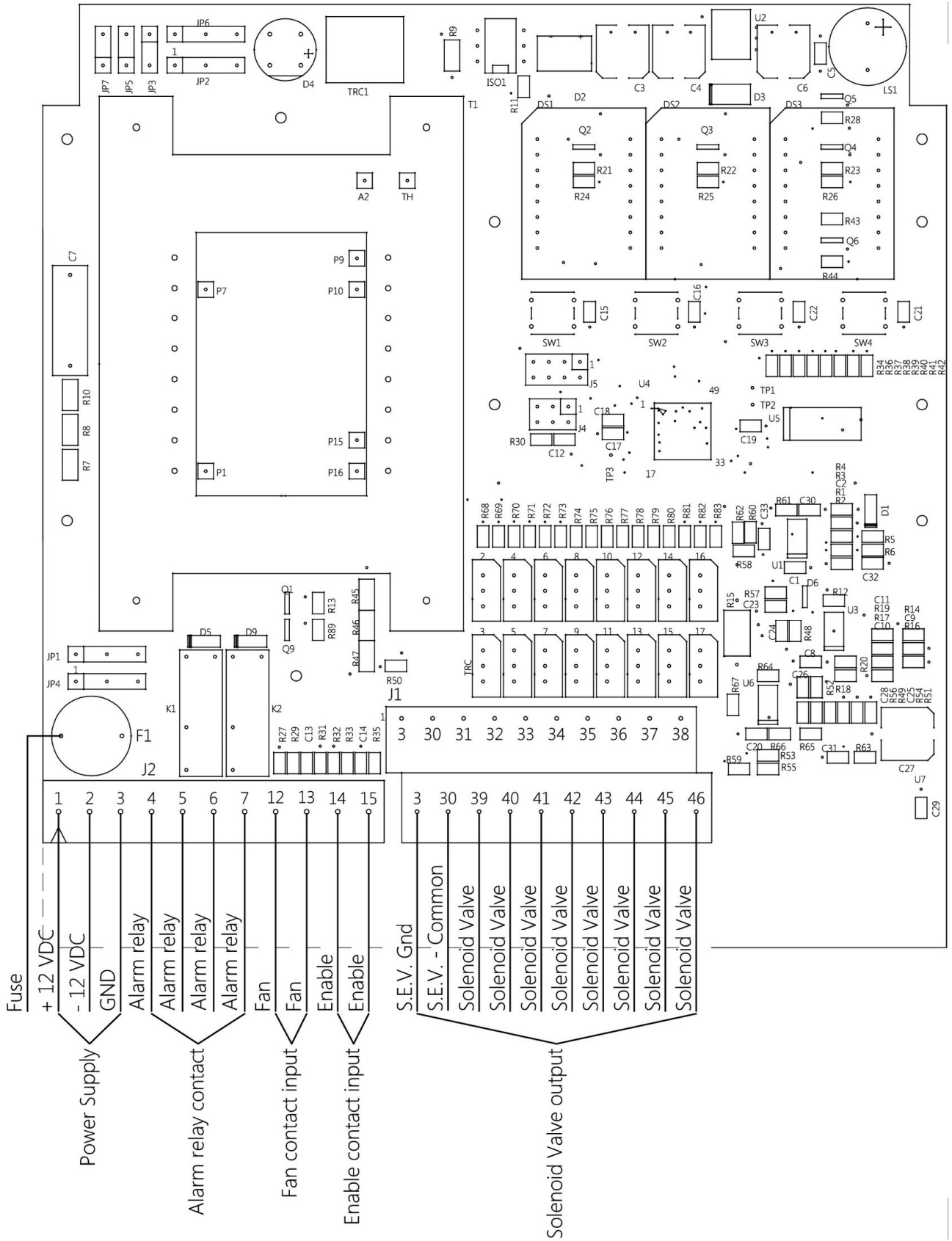

Contacts And Relay Terminal Block J2

Enable contact input consensus 14.15 terminals.

Is used to activate the control unit remotely, it can be turned on and off remotely.

The unit is supplied with a jumper on the two terminals 14:15, without it will not turn on.

Fan contact 12.13 input terminals.

Indicated by the control unit that the plant has been started and is in operation.

The unit is supplied with a jumper on two 12:13 terminals to simulate the state of the plant, as if the fan was turned on.

Alarm Relay K1 4.5 terminals.

The relay is normally closed, opens in case of alarms, and opens with the control unit off or in the absence of power.

The alarms that open the relays are:

Problem with solenoid valves E06-E08.

Maintenance interval has been reached.

If one of these occurs, the relay is activated.

Terminal Table

Terminal n.	Description	Terminal n.	Description
1	Power supply + 12 Vdc	32	Solenoid 2 output
2	Power supply - 12 Vdc	33	Solenoid 3 output
3	Earth (GND)	34	Solenoid 4 output
4	Relay contact 1	35	Solenoid 5 output
5	Relay contact 1	36	Solenoid 6 output
6	Relay contact 2	37	Solenoid 7 output
7	Relay contact 2	38	Solenoid 8 output
12	Fan input	39	Solenoid 9 output
13	Fan input	40	Solenoid 10 output
14	Enable input	41	Solenoid 11 output
15	Enable input	42	Solenoid 12 output
		43	Solenoid 13 output
3	Solenoid Valve Gnd	44	Solenoid 14 output
30	Solenoid Valve Common	45	Solenoid 15 output
31	Solenoid 1 output	46	Solenoid 16 output

If the sequencer is in G2 version with reinforced power supply, connect two solenoid valves in parallel to each terminal.

Fuse Table

Voltage	Value
12 Vdc	3 A

Jumper Configuration Output

12 Vdc

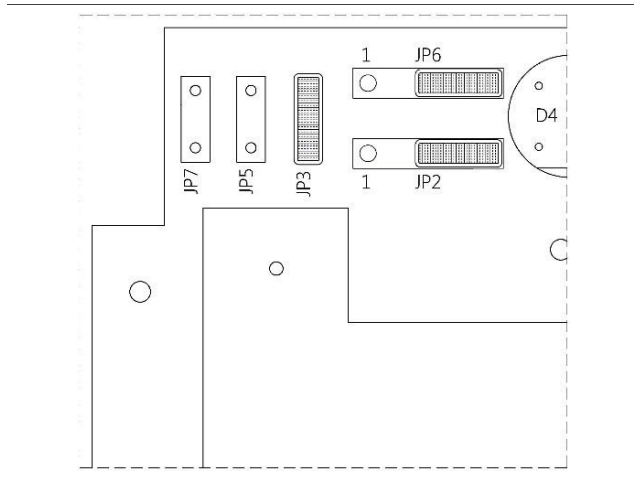

Installation – Casing Dimensions 4 - 8 Outputs

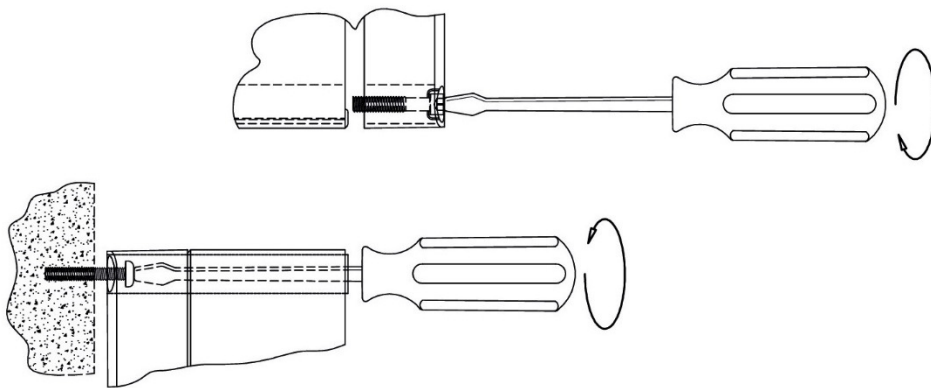
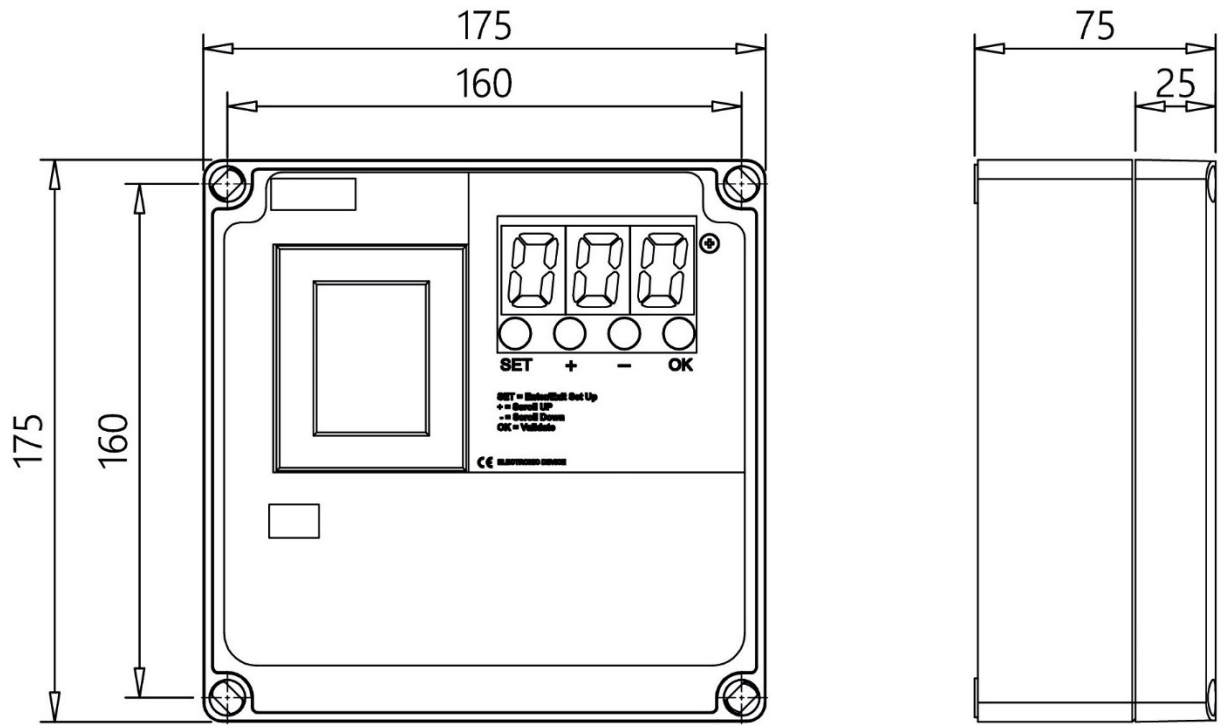

Weight 0.8 Kg

Installation – Casing Dimensions 12 - 16 Outputs

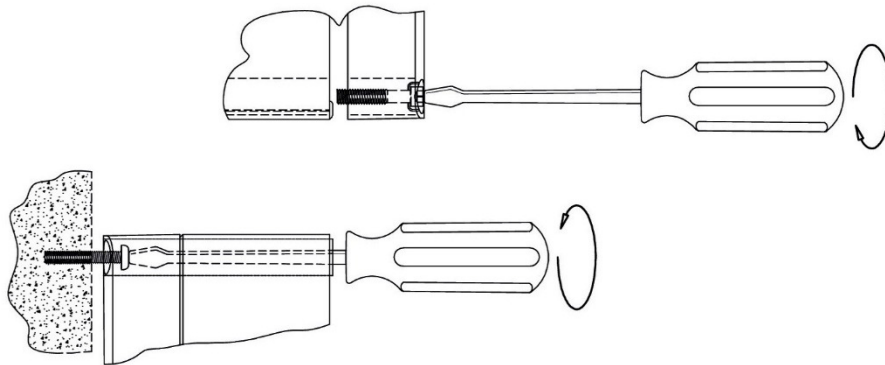
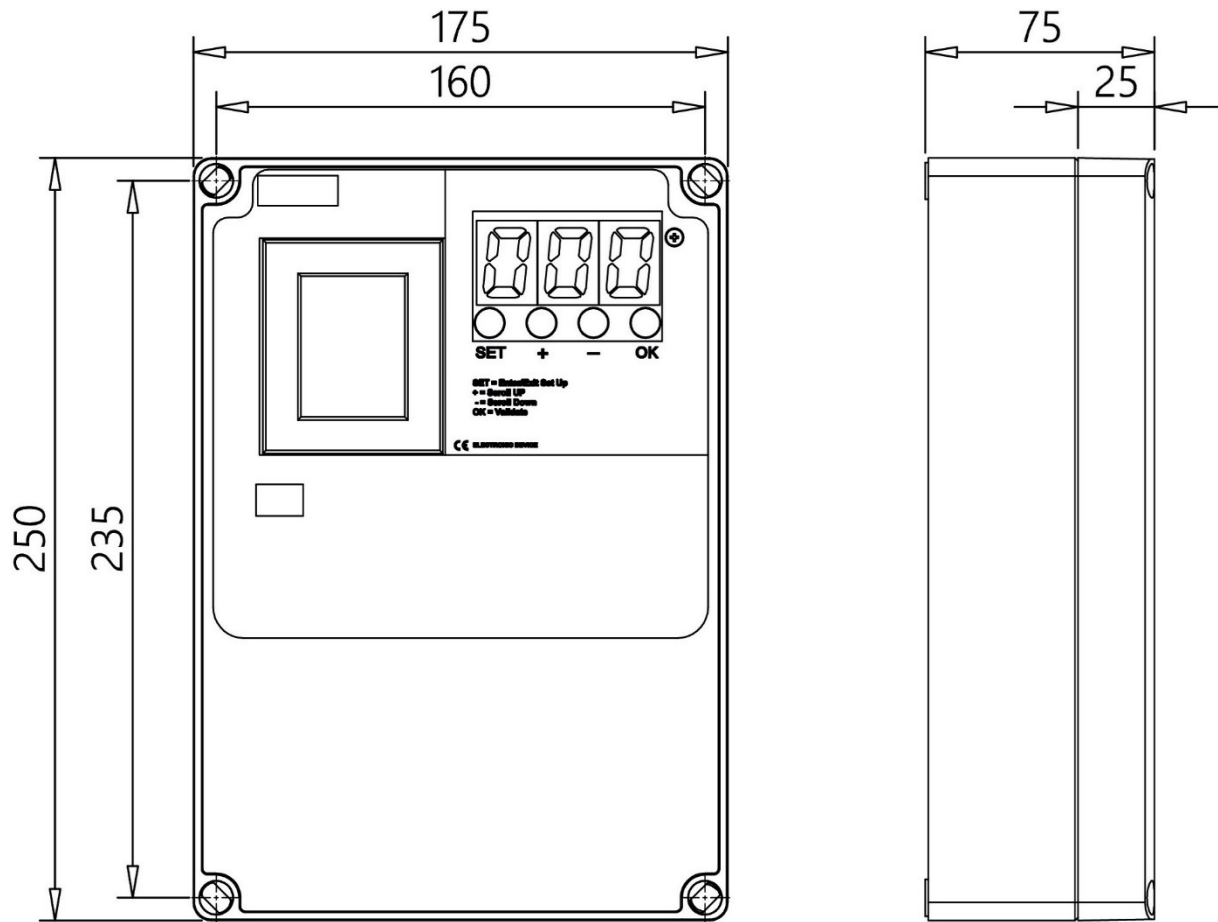

Weight 1.2 Kg

Maintenance

The only parts which may be replaced are fuses. All other operations must be carried out by the manufacturer.

Scrapping

Dispose of properly after use. Dispose of the product according to laws in force for electronic equipment.



This device is for use in a dust collection system and is therefore part of a fixed installation.

Default Settings

The default settings are:

Function Number	Description	Set Value
F02	Solenoid valve activation time.	0.20 Sec.
F03	Pause time between solenoid valves in normal cycle.	020 Sec.
F04	Number of outputs.	1
F05	Output voltage: 12 Vdc.	12 Vdc
F06	Manual solenoid valve activation.	1
F13	Number of cycles after fan stop.	1
F14	Pause time between solenoid valves in cycle with fan off.	010 Sec.
F15	Maintenance frequency in 10h (1=10h, 100=1000h).	100
F16	Maintenance deadline alarm on (1) or off (0).	0
F17	Maintenance hour counter reset: set 1 and confirm to reset the maintenance hour counter.	0
F24	Exclusion of valve in short circuit.	0

Warranty

The warranty lasts for 2 years. The manufacturer will replace any faulty electronic component at their own facilities only, unless otherwise authorised by the manufacturer.

Warranty Exclusions

The warranty will be cancelled in case of:

- Signs of unauthorised tampering and repairs.
- Incorrect use of the device not respecting technical data.
- Incorrect electric connections.
- Failure to respect system standards.
- Use not in accordance with EC standards.
- Atmospheric events (lightening, electrostatic discharges, power surges).

Problem Solution FAQ

Fault	Possible Cause	Solution
The display does not light up.	Burnt fuse.	Check the protection fuse on the power voltage. Check that the power voltage is present and compliant with that required for the device (terminals 1, 2 and 3).
The outputs are not activated.	Incorrect output voltage. Wiring to solenoid valves.	Check that the unit and solenoid valve output voltage agree. Check wiring between sequencer and solenoid valves.
Do alarm messages appear?		Check the alarm code with the table.
Do the alarms fail to activate signalling devices?	System wiring errors. No power to alarm devices.	The alarm devices must be powered by voltage external to the sequencer. Activating to open the respective relay.
The sequencer resets occasionally	Check the there is no filtered pulse load on the power line (spot welding machines, welding machines, plasma cutters etc.).	Install a filter on the power line of the sequencer, if needed.

Declaration Of Conformity Of The Manufacturer



The Manufacturer:

TURBO SRL

The Manufacturer's Address:

Via Po 33/35 20811 Cesano Maderno (MB), Italy

Declares That

Product Name:

Sequencer E1T

Models:

E1T 4 - 16

Product Options:

All

Complies with the following directives:

Electromagnetic Compatibility Directive 2014/30/EU, meeting EU harmonised standards EN61000-6-2:2005 class B of Standard EN61000-6-4:2001.

Low Voltage Directive 2014/35/EU meeting EU harmonised standards EN 60947-1:2004.

A typical configuration of the product was tested.

Cesano Maderno, 01/03/2016

F. MESSINA (C.E.O.)

A handwritten signature in black ink, appearing to read 'Messina F. Giovanni', is written over the printed name 'F. MESSINA (C.E.O.)'.

TURBO s.r.l.

Code And Serial Number