



TURBO s.r.l.
Electronic Control Systems For Dust Collectors
e-mail: info@turbocontrols.it
web: www.turbocontrols.eu
TEL. ++39 (0)362 574024
FAX ++39 (0)362 574092

ECONOMISER SERIES E2T 24Vac USER MANUAL



01/03/2016
Manual Release 1.25
Hardware Release 1.3

General Description

Economiser for controlling the pneumatic cleaning function of industrial dust collection systems. The pressure differential is digitally controlled by an internal transducer allowing to determine filter obstruction with accuracy. It has 2 output relay contacts and 2 digital input contacts. A large, bright display is provided for reading the filter obstruction level, the active solenoid valves and any alarms in any moment.

Technical Specifications

Casing

- Made of insulating, ABS base and polycarbonate lid.
- Degree of protection to water and dust: IP65 (EN60529).
- Shock resistance: IK08/07 2 Joule (EN62262).

Performance Of The Device

- LED display with 7 segments, 3 digits, 0.8" each.
- Four operation modes: manual; automatic; automatic with forced cycle; proportional.
- Operating times expressed in seconds with selectable ranges for any application.
- Pressure measurements expressed in kPa.
- Power voltage 24 Vac.
- Output voltage 24 Vac, 24 Vdc selectable by means of jumper, must also set with F05.
- Washing function with the fan off (post-cleaning) through the "dP fan" threshold in the automatic/automatic with forced cycle/proportional modes and through contact in the manual mode with up to 99 cycles that can be selected.
- Total and partial hour counter for maintenance.
- Two alarm relays, normally closed.
- Maximum dP (filter obstructed) alarm.
- Minimum Δp alarm (broken sleeve/cartridge), with possibility of inclusion/exclusion.
- Solenoid valve not working alarm.
- Filtering element maintenance deadline alarm (with on/off selection).
- External contact cleaning activation.
- Compressed air presence enable input.
- Pre-coating function (with possibility of inclusion/exclusion).
- Active 4-20mA output proportional to dP reading for remote pressure reading.
- Manual solenoid valve activation.

Electric Specifications

Electric Power

- 24 Vac \pm 10% 50-60 Hz – 25W



Important: Read the installation instruction section before connecting the device.

Selectable Output Voltage

- 24 Vdc
- 24 Vac

Inputs And Outputs Not Galvanically Insulated

- Enable contact (remote cleaning enable).
- Fan contact (post-cleaning).
- 4 – 20mA (dP remote reading).

The solenoid valves connected to the unit are normally closed.

The activation of a solenoid valves causes them to open and consequently let out a jet of air.

Alarm Relay

The two alarm relays contain 2 clean contacts on terminals 4-5 and 6-7.

Maximum permitted load: 2A @ 24 Vdc, Vac.

The relays are normally closed, opens in case of alarm, and opens to the control unit off in the absence of power.

Fuses:

1 x 3 A @ 24 Vac.

Working Temperature

from -10°C to 55°C

Storage Temperature

-20°C to 60°C

Timer Specifications

Pulse time (valve opening)

from 50 ms to 5 sec

Pause time (interval between valve openings)

1 sec - 999 sec



Important: Higher pressures may damage the device. Do not connect the obstruction measuring pipes to the compressed air circuit.



Differential Pressure Gauge:

Measurable pressure range: from 0 to 4 kPa



Maximum applicable pressure: 16 kPa - 0.16 bar

Warning Symbols Used In This Manual

The information regarding safety are highlighted using the symbols:

	Warning-Danger	Generic - Warning-
	Risk – Danger	Electric Current
	Dispose according to the standards for electrical and electronic equipment RAAE	

Installation Rules Notes and Warnings

- ⇒ Protect the device from direct exposure to sunlight.
- ⇒ Do not position the device near or directly in contact with sources of heat or electromagnetic fields. 
- ⇒ Fix the device of a height of at least 60 cm from the ground.
In a clearly visible place easily accessible.
- ⇒ Connect the device to power lines other than those for operating motors or other large power devices which could generate network interference or instability.
- ⇒ The electrical supply of the unit must be protected by a differential switch 230Vac~ 30mA and a bipolar magneto thermic 230Vac~ 10A, positioned in a place easily accessible.
- ⇒ Before working on the equipment to perform any operation switch off the magneto thermic differential switch. 
- ⇒ For electric operations, always remove voltage, wait 30 seconds for the inside capacitors to discharge before opening. At the end of the operations, close the device to restore the correct degree of protection before powering up.
- ⇒ For the connection of the supply voltage, use anti-flame wires with a minimum section of 0.75mm² certified and conform to the standard IEC60227 or IEC60245.
- ⇒ Use flame-retardant cables with a minimum cross-section area of 0.75 mm² for all control signals.
- ⇒ Use flame-retardant cables with a minimum cross-section area of 0.75 mm² to connect to the indicating relays.
- ⇒ Use flame-retardant cables with a minimum cross-section area of 0.5 mm² for electro valves control signals.
- ⇒ The wire ground conductor of protection must be yellow/green.
- ⇒ The wire ground conductor of protection must be connected first.
- ⇒ The wire which is colored yellow/green must only be used for the ground conductor.

- ⇒ The cable glands must be chosen according to the diameter of the cable to be used.
- ⇒ The sealing of the press cable is guaranteed by the compression of the rubber gasket that tightens on the outer diameter of the cable.
- ⇒ The tightness of the cable gland is guaranteed by the compression of the rubber seal that tightens on the outer diameter of the cable.
- ⇒ The size of cable and cable gland must ensure that a power cord traction is not acting on the terminals.
- ⇒ The terminal block must not be the point of mechanical anchoring of the conductors.
- ⇒ The cable gland PG9 supplied on request, has cable diameter minimum of 4mm and a maximum of 8mm, with clamping nut by 19mm.
- ⇒ Any use not described in this user instruction manual or incorrect use of the device may cause damage to the device or to the devices connected to it.
- ⇒ Furthermore, incorrect use or tampering with the device may cause injury.
- ⇒ Waterproofness of the casing is guaranteed when the flap is closed.
- ⇒ Make sure that rigid or flexible ducts used for wiring, if any, do not fill up with water or other liquids.
- ⇒ Do not make holes not protected on the container or protected by accessories with protection degree lower than that of the housing of the control unit.
- ⇒ Cut off power supply immediately if water is found in the casing.
- ⇒ If the control unit is used in ways not specified by the manufacturer, the protection provided by the device may be impaired.
- ⇒ The Control Unit does not release potentially toxic or harmful substances to the health and the environment.
- ⇒ No part with dangerous voltage is normally accessible.

Do not use the control unit if you have not read or do not understand this manual.

Display / Keypad

There are four round buttons on the front panel for controlling the device and turning on the display as shown in the following figure.

- The SET button enables to enter and exit the programming menu, and activate the manual testing of selected solenoid valve function F06.
- The + and - buttons enable to scroll functions from F01 to Fxx. After entering one of the Fxx functions use the OK button to select and then + and - increase or decrease the values.
- The OK button is used to confirm data and reset alarms.
- If the + button is pressed during ordinary operation, the activity hour meter is displayed.
- The - Button pressed during the ordinary operation, displays the counts partial hours of activity.

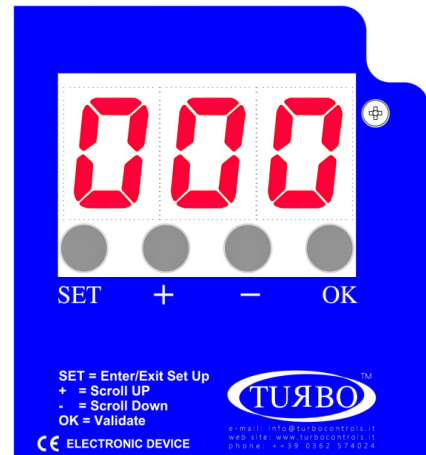

Menu Diagram

- Press SET, the letter F flashes.
- Press + and - to select the required function.
- Press OK to confirm.
- Increase or decrease the value of the parameter.
- Holding down the + and - buttons to scroll through all the functions until the end of the left or right.
- Press OK to confirm and exit.
- Press SET again to exit programming mode.



List Of Functions

➤ **F01:**

Configuring the operation mode.

Possible values: 0 – Manual (dP excluded)
 1 – Automatic (dP included) Default
 2 – Automatic with forced cycle (dP included)
 3 – Proportional (dP included)

By setting the Manual Mode, it is necessary change the value of F11 Fan Recognition on 0, detection by contact and not by dP, close together the contacts to 12:13 on J2 terminal block.

➤ **F02:**

Solenoid activation time.

Possible values: 0.05" – 5.00" step 0.01".
 Default = 0.20".

➤ **F03:**

Washing pause time between solenoid valves.

Possible values: 001" – 999" step 1".
 Default = 20".

➤ **F04:**

Number of connected outputs.

Possible values: 01 – 16 step 1.
 Default = 001.

➤ **F05:**

Output voltage setting, must agree with jumpers.

Possible values: d24, a24.
 Default = a24.

➤ **F06:**

Manual output activation.

Possible values: 1 – number of outputs set in F04.
 Press SET to activate the set output.

➤ **F07:**

Zero dP threshold.

Possible values: 0.00 kPa – 3.99 kPa step 0.01.
 Default = 0.00 kPa.

➤ **F08:**

Cleaning cycle start threshold high dP set point.

Possible values: 0.00 kPa – 3.99 kPa step 0.01.
 Default = 0.80 kPa.

➤ **F09:**

Cleaning cycle stop threshold low dP set point.

Possible values: 0.00 kPa – 3.99 kPa step 0.01.
 Default = 0.40 kPa.

➤ **F10:**

Max dP Alarm Threshold (Filter Clogging if detected for longer than 20 seconds)

Possible values: 0.00 kPa – 3.99 kPa step 0.01.
 Default = 3.00 kPa.

➤ **F11:**

Fan on recognition mode for after cycle cleaning.

Possible values: 0 from contact – 1 from dP.
 Default = 1 from dP.

Set to 0 if F01 is 0, Manual Mode dP excluded.

➤ **F12:**

dP threshold for fan on recognition if F11=1.

Possible values: 0.00 kPa – 3.99 kPa step 0.01.
 Default = 0.10 kPa.

- **F13:**
Number of post cleaning cycles after stopping the fan.
Possible values: 01 – 99 step 1.
Default = 01.
- **F14:**
Post cleaning mode pause time between solenoid valves (fan off).
Possible values: 001" – 999" step 1".
Default = 10".
- **F15:**
Maintenance frequency expressed in tens of hours (e.g.: 1=10h, 10=100h).
Possible values: 001 – 999 step 1.
Default = 100 (=1000h).
- **F16:**
Maintenance deadline alarm enable.
Possible values: 0 (disabled) – 1 (enabled).
Default = 0 (disabled).
- **F17:**
Maintenance hour counter reset.
Possible values: 0 (disabled) – 1 (reset).
Default = 0 (disabled).

The maintenance hour counter will be reset and the F17 parameter will be set back to 0 by setting F17 to 1.
- **F18:**
Precoating function enabling.
Possible values: 0 (disabled) – 1 (enabled).
Default = 0 (disabled).
- **F19:**
dP threshold for precoating function.
Possible values: 0.00 kPa – 3.99 kPa step 0.01.
Default = 2.00 kPa.
- **F20:**
Enabling Minimum dP Alarm function if detected for longer than 60 seconds.
Possible values: 0 (disabled) - 1 (enabled).
Default = 0 (disabled).
- **F21:**
Min dP Alarm Threshold (Broken Sleeve/Cartridge)
Possible values: 0.00 kPa – 3.99 kPa step 0.01.
Default = 0.20 kPa.
- **F22:**
Selection of minutes or hours for Forced Cleaning Cycle. (Only if the operating mode F01 = 2)
Default = Minutes (0 =minutes, 1 =hours).
- **F23:**
Setting time interval for Forced Cleaning Cycle in relation to the choice of F22.
Setting values: 1 - 999 step 1.
Default = 240 (240 minutes).
- **F24:**
Exclusion of valve in Short Circuit.
The default setting is 0, the valve in Short Circuit is tested at each cycle.
If set to 1, when a valve is in short circuit is excluded from the cycle and is not rechecked.

Alarms

The unit runs a number of checks during the start-up cycle and during normal operation. The possible alarms and respective solutions are shown in the following table.

No.	Description	Action
E01	F05 set to 24 Vdc Vac jumper detected	- For 24 Vdc, switch the device off and move the AC/DC jumpers to DC. - For 24 Vac, press OK, then press SET, set the function F05 using "+" and "-", select A24 and press OK to confirm.
E02	F05 set to 24 Vac Vdc jumper detected	- For 24 Vac, switch the device off and move the AC/DC jumpers to AC. - For 24 Vdc, press OK, then press SET, set the function F05 using "+" and "-", select d24 and press OK to confirm.
E03	F05 set to 24 Vac or Vdc. Voltage out of range detected	- To use 24V valves, switch the device off and move the output voltage selection jumper to 24V. - If the jumper is in the correct position, press OK, then SET, select the F05 function with "+" and "-", set 115 or 230 (as jumper) and press OK.
E06	Solenoid valve current lower than minimum threshold or disconnected solenoid valve	Check correct connection of the solenoid valve and respective data. The alarm is self-reset.
E07	Solenoid valve current higher than maximum threshold	Check correct connection of the solenoid valve and respective data. The alarm is self-reset.
E08	Output short circuit. Alarm The signaling of the code E08 alternates with the indication of the interested output is shown as Uxx where xx is the number of the output and the value of dP.	Switch the device off and back on after having checked the solenoid valve system.
E09	dP maximum pressure exceeded (F10) Detected for longer than 20 seconds.	Check state of filtering elements.
E10	dP sensor hardware offset out of range.	The self-calibration of the dP sensor has determined that a value is out of range. Disconnect the air tubes and repeat the function. Take the device to be serviced if the alarm occurs again.
E11	Maintenance deadline reached	Carry out maintenance.
E12	dP sensor full-scale value reached Immediate reporting without any delay.	Check state of filtering elements. IMPORTANT: Running in this condition may damage the device.
E13	Minimum dP alarm value ranging from F12 to F21 (warning: the alarm is generated with a fixed delay of 60 seconds).	Check the status of the filtering elements.
E14	Indicates that a valve in short circuit has been excluded from the cycle. The signaling of the code E14 alternates with the indication of the interested output is shown as Uxx where xx is the number of the output and the value of dP. An output is considered a short circuit if not responding for 3 following activations. An activation without error resets the counting.	Switch the device off and back on after having checked the solenoid valve system.

Description Of Operation

The installed SW version and the symbol ---, meaning that coherence between settings stored in E2Prom and the set jumpers is being checked, will appear on the display when the economiser is powered up. A corresponding error code will appear in case of discrepancies between settings (see Alarms Table). Only editing functions will be allowed on the unit. The operator may switch off the unit and configure the jumpers correctly.

Symbol 0_0 will appear on the display if the test is entirely successful. The following pages will then appear:

- In automatic mode (F01=1):
 - dP value alternating with OFF if the enabling contact (14-15) is open
 - dP value alternating with -0- if the enabling contact (14-15) is closed and the fan is off
 - dP value only if the fan is enabled and active.
- In manual mode (F01=0):
 - OFF if the enabling contact is open (14-15)
 - -0- if the enabling contact (14-15) is closed and the fan is off

Manual Operating Mode F01=0

The economiser will work as a programmable cycle sequencer in manual mode. The connected outputs will be activated at the programmable frequencies. Manual mode can be activated by accessing the configuration menu and setting F01 to 0. F02 and F03 will set the activation time and the pause time, respectively.

Automatic Operating Mode F01=1

By selecting automatic mode (F01=1), the economiser will work autonomously can carry out the pneumatic washing cycle only when needed. The device will start the washing cycle if the obstruction is higher than Threshold_dP_Start (F08). Washing is suspended when obstruction drops under Threshold_dP_Stop (F09) level until it reaches a value higher than the Threshold_dP_Start threshold once again. When washing is active, the economiser respects the times set in F02 (operating time) and F03 (pause time).

Automatic Mode With Forced Cycle F01 = 2

Identical to the automatic mode, except for the fact that it is possible to obtain a cleaning cycle with the activation of the solenoid valves connected without reaching the Threshold_dP_Start (F08). The forced cleaning interval may range from 1 to 999 h and can be selected through function F22 and F23.

Proportional Mode F01 = 3

With the proportional mode, the economiser will work in full autonomy, initially setting the dP_Start threshold (F08), activation time (F02) and pause time (F03).

When the Start Cleaning threshold is exceeded, the solenoid valves are automatically activated in sequence. If the dP threshold drops below 15% at the end of an entire cycle of pulses of the connected solenoid valves, the washing is suspended until pressure returns to a value above the Start Cleaning dP value. If the dP value does not drop below 15% of the Start Cleaning threshold, the frequency of the cycle time is automatically reduced in proportion with each entire cycle of pulses of the connected solenoid valves, until a minimum cycle time between solenoid valves reaches 10 seconds. The minimum threshold of 10 seconds has been chosen so as not to hamper the dispensing of air by the compressor connected to the filter.

Cleaning Function With Fan Off (PCC)

This function allows to carry out one or more cleaning cycles (the number of cycles is defined by F13) when the fan is off. The on or off state of the fan may be determined by the state of the contacts 12-13 (contacts open = fan off) if F11=0, or may be determined automatically (with F11=1) when the dP pressure drops under the threshold defined in F12. The pulse time of the valves will always be that defined in F02, while the pause time in this case is defined in F14.

The display alternately shows the number of the valve activated and the word PCC.

Number Of Output Selection

The number of outputs (solenoid valves) on which the economiser will run the cleaning cycle can be selected. Cleaning will be carried out in order from the first to the last solenoid valve. The valves can be adjusted by the F04 function.

Precoating Function (F18=1)

This function is used to carry out precoating. Precoating is a filtering element treatment carried out with precoating powder. Washing and manual output activation is suspended during precoating until the precoating thresholds defined in F19 is reached.

The dP value and the message PC (precoating) will appear alternatively on the display.

dP Zero Calibration (F07)

This function is used to reset dP reading with the fan off.

Increase or decrease the value shown by pressing "+" and "-" as required. This value will be subtracted from the value read by the dP sensor.

dP Sensor Self-Calibration

This function allows to reset dP reading with the fan off automatically.

Hold "SET" and "OK" pressed at the same time with the device off. The message "CAL" will appear after the start-up test. Release the buttons. The unit will go back to normal state after a few instants. Automatic calibration is complete.

Fuse

A fuse which can be reset in case of need is located near the power terminal board. Use a delayed fuse 5x20mm.

Connection Diagram

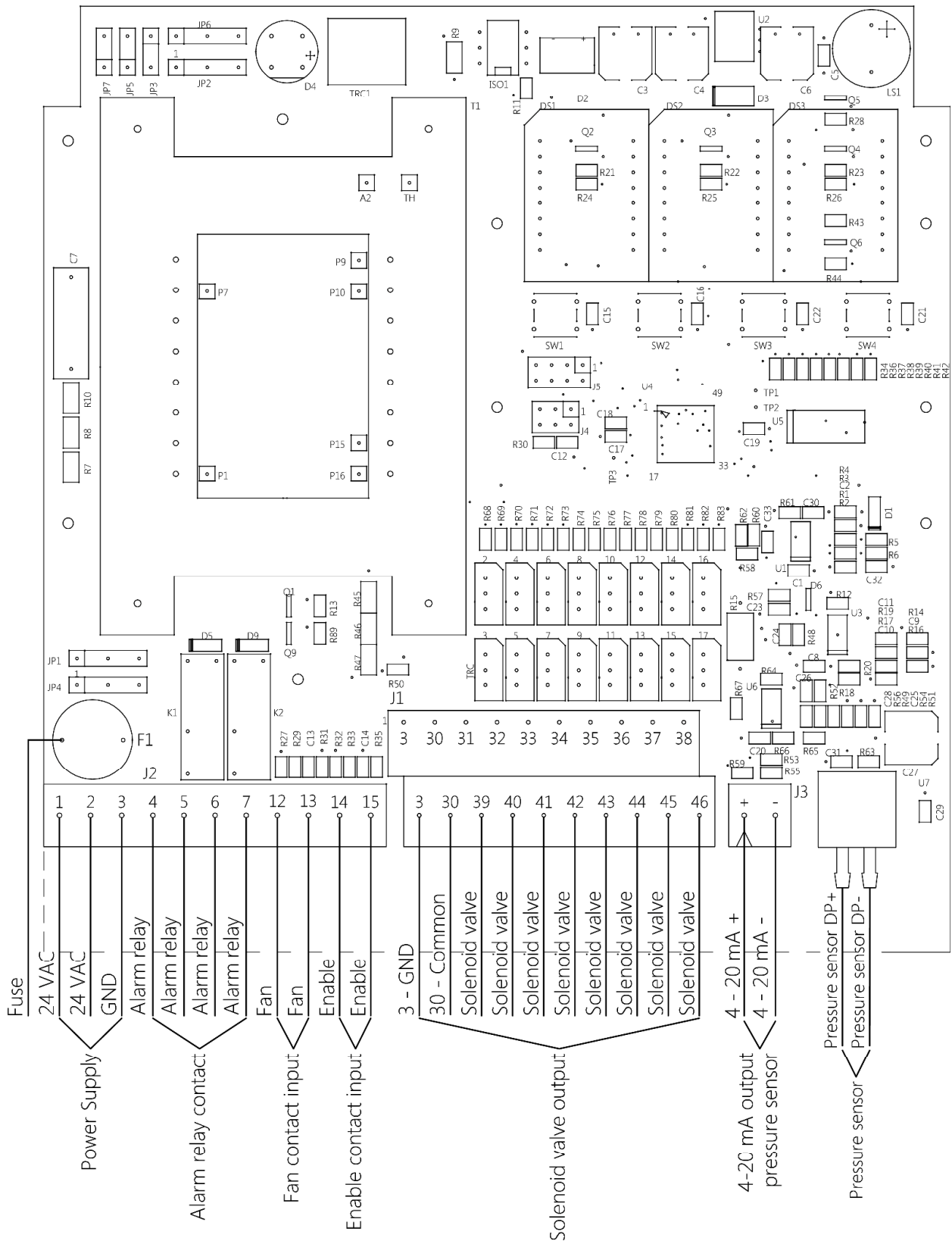

Pressure Sensor	dP + Pressure inlet dirty section
	dP - Depression inlet clean section

Contacts And Relay Terminal Block J2

Enable contact input consensus 14.15 terminals.

Is used to activate the control unit remotely, it can be turned on and off remotely.

The unit is supplied with a jumper on the two terminals 14:15, without it will not turn on.

Fan contact 12.13 input terminals.

Indicated by the control unit that the plant has been started and is in operation.

The unit is supplied with a jumper on two 12:13 terminals to simulate the state of the plant, as if the fan was turned on.

Alarm Relay K1 4.5 terminals.

The relay is normally closed, opens in case of alarms, and opens to the control unit off in the absence of power.

The alarms that open the relays are:

Max dP has been reached.

Min dP has been reached.

Problem with solenoid valves E06-E08.

Maintenance interval has been reached.

If one of these occurs, the relay is activated.

Alarm Relay K2 6.7 terminals.

The relay is normally closed, opens in case of alarm, and opens to the control unit off in the absence of power.

The alarm that open the relays is:

Max dP has been reached.

Terminals Table

Terminal n.	Description	Terminal n.	Description
1	Power supply 24 Vac	33	Solenoid 3 output
2	Power supply 24 Vac	34	Solenoid 4 output
3	Earth Gnd	35	Solenoid 5 output
4	Relay contact	36	Solenoid 6 output
5	Relay contact	37	Solenoid 7 output
6	Relay contact	38	Solenoid 8 output
7	Relay contact	39	Solenoid 9 output
12	Fan input	40	Solenoid 10 output
13	Fan input	41	Solenoid 11 output
14	Enable input	42	Solenoid 12 output
15	Enable input	43	Solenoid 13 output
		44	Solenoid 14 output
3	Solenoid Valve Ground	45	Solenoid 15 output
30	Solenoid Valve Common	46	Solenoid 16 output
31	Solenoid 1 output	11	"+" 4-20mA dP output
32	Solenoid 2 output	10	"-" 4-20mA dP output

If the economiser is in G2 version with reinforced transformer, connect two solenoid valves in parallel to each terminal.

Fuse Table

Voltage	Value
24 Vac	3 A

Jumper Configuration - Output

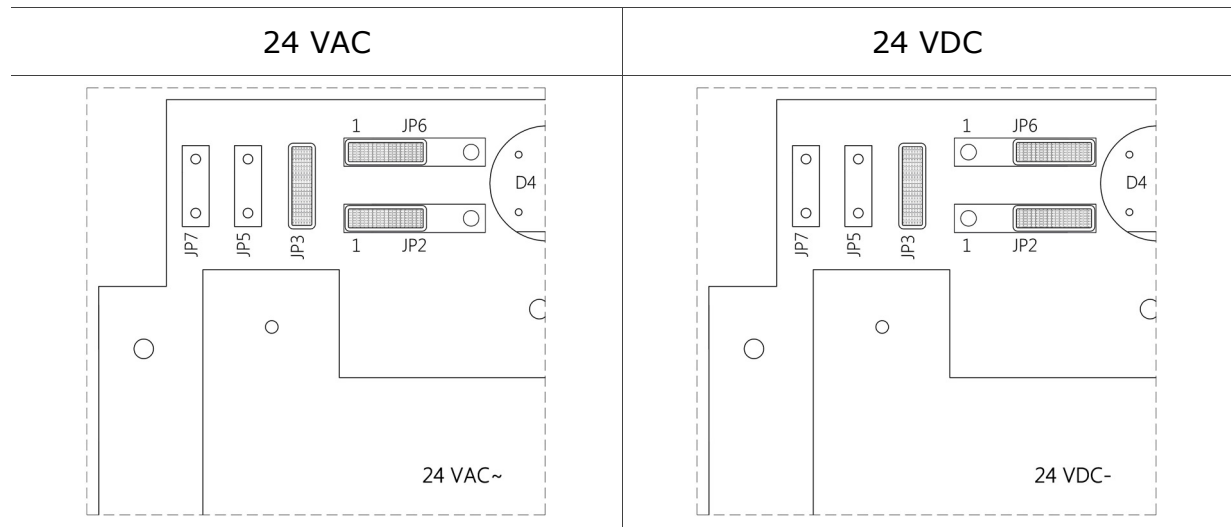

Installation - Casing Dimensions 4 / 8 Outputs

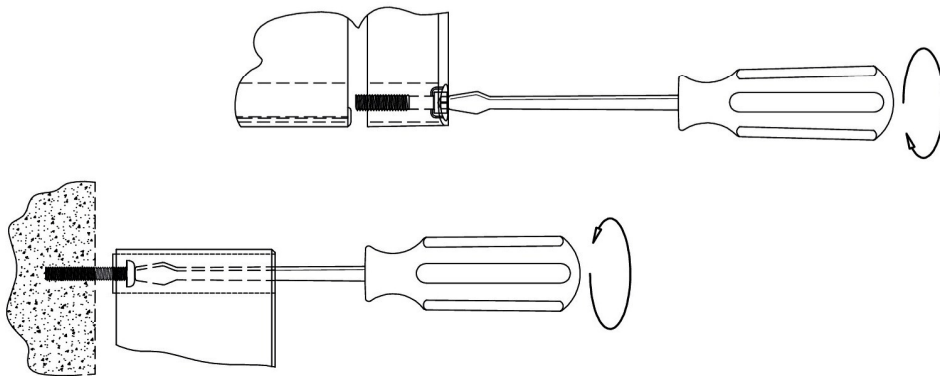
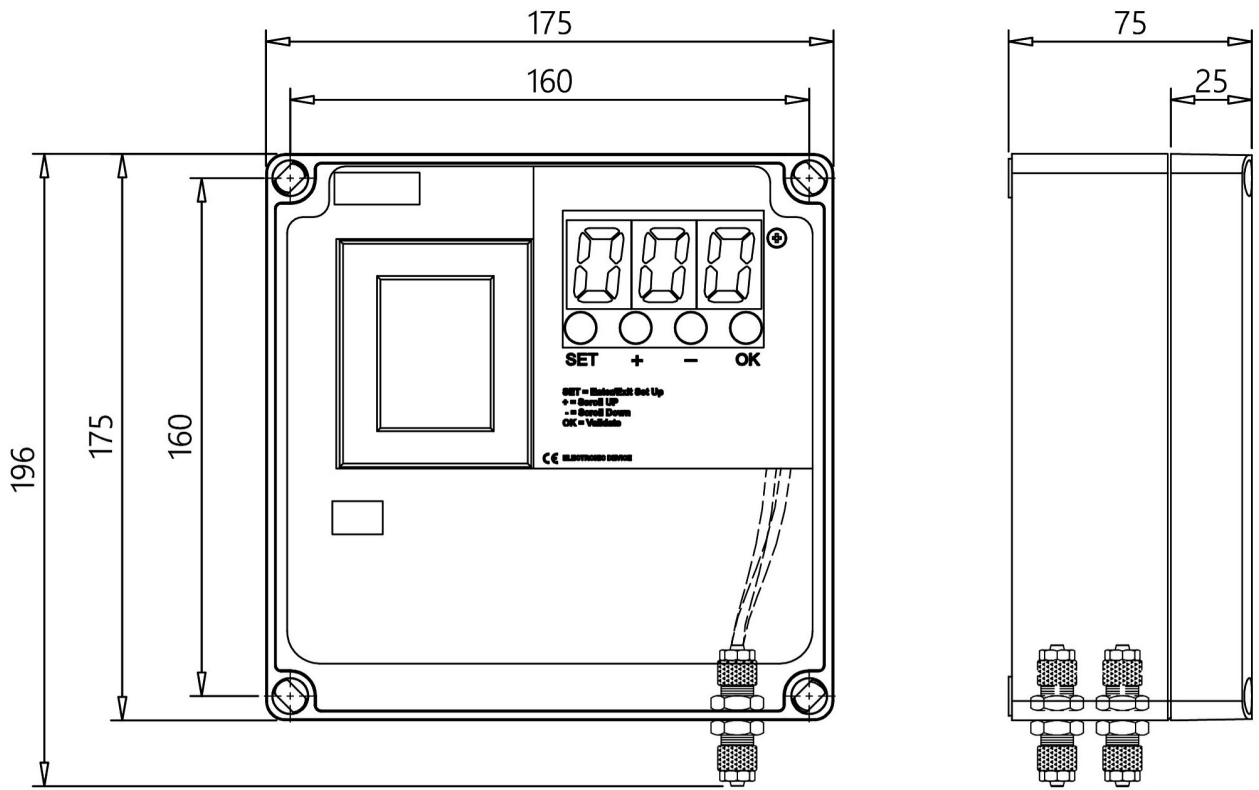

Weight 1.8 Kg

Installation - Casing Dimensions 12 / 16 Outputs

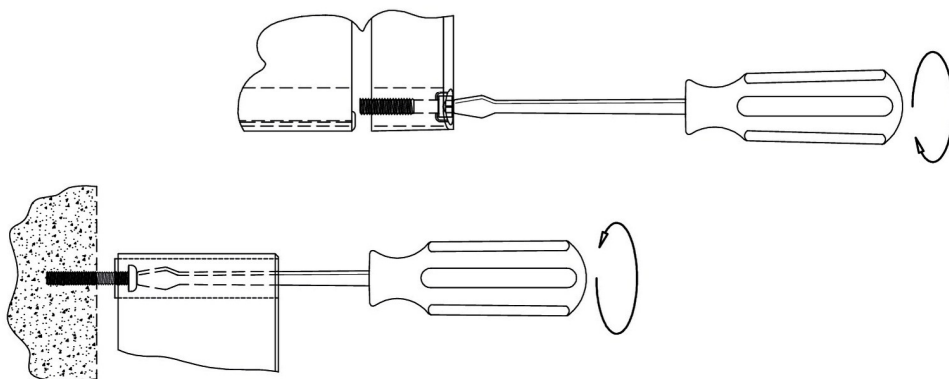
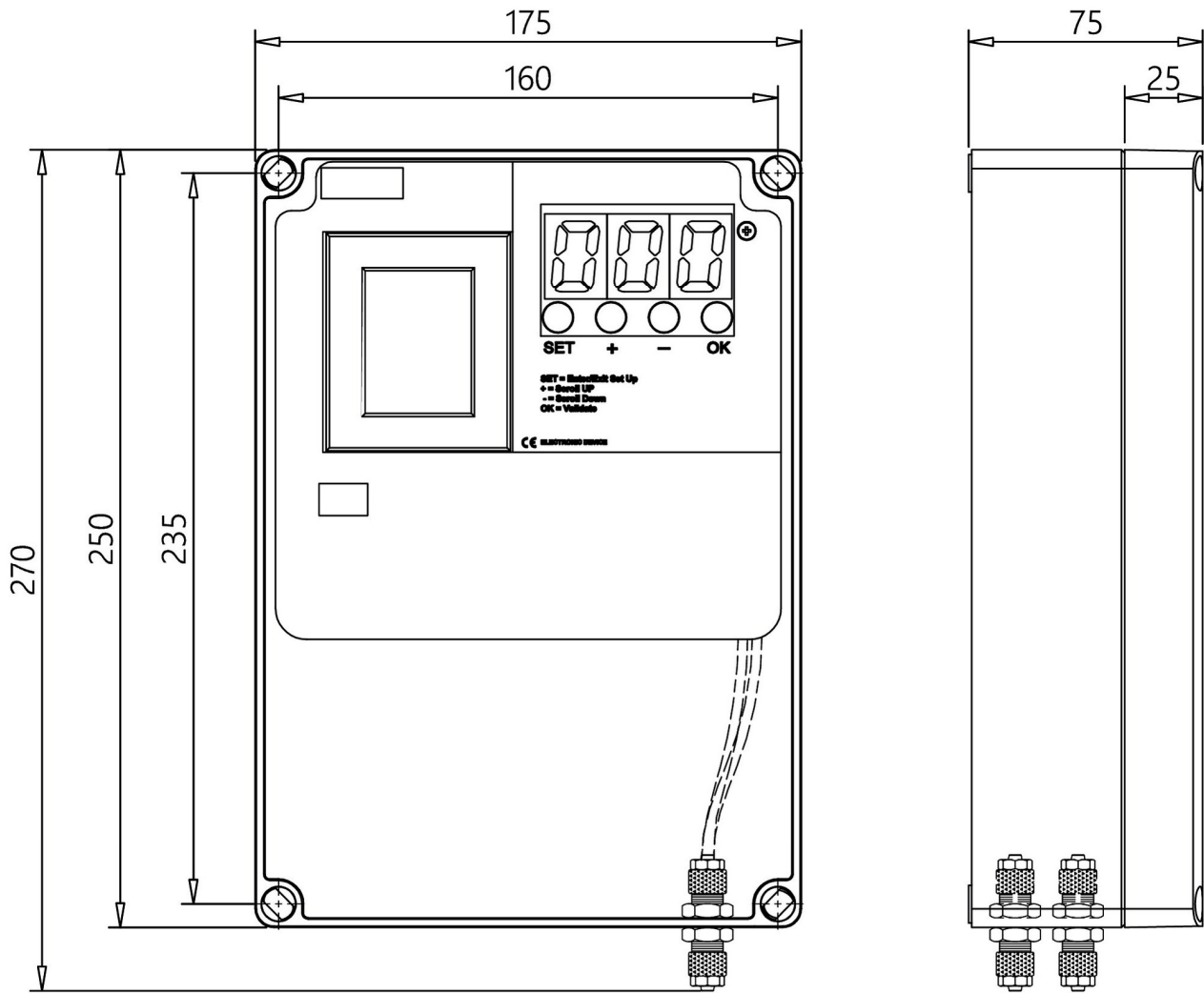

Weight 2.1 Kg

Maintenance

The only parts which may be replaced are fuses.
All other operations must be carried out by the manufacturer.

Scrapping

Dispose of properly after use. Dispose of the product according to laws in force for electronic equipment.



This device is for use in a dust collection system and is therefore part of a fixed installation.

Default Settings

The default settings are:

Function Number	Description	Set Value
F01	Automatic setting using dP (1) or manual (0)	1
F02	Solenoid valve activation time	0.20"
F03	Washing pause time between solenoid valves in normal cycle	020"
F04	Number of outputs	1
F05	Output voltage: 24 Vdc, 24 Vac.	24 Vac
F06	Manual solenoid valve activation	1
F07	Zero dP threshold	0 kPa
F08	Cycle start dP threshold	0.80 kPa
F09	Cycle stop dP threshold	0.40 kPa
F10	Max. dP level	3.00 kPa
F11	Fan mode: 0 from contact , 1 from dP	1
F12	Fan dP threshold (if F11 = 1). If < fan off	0.10 kPa
F13	Number of cycles after fan stop	1
F14	Pause time between solenoid valves in cycle with fan off	010"
F15	Maintenance frequency in 10h (1=10h, 100=1000h)	100
F16	Maintenance deadline alarm on (1) or off (0)	0
F17	Maintenance hour counter reset: set 1 and confirm to reset the maintenance hour counter	0
F18	Precoating on (1) or off (0)	0
F19	Precoating dP threshold (if F18 = 1).	2.00 kPa
F20	Enabling Minimum dP Alarm function.	0
F21	Min dP Alarm Threshold (Broken Sleeve/Cartridge)	0.20 kPa
F22	Cleaning Cycle Forced (only available in operating mode F01 = 2) Set if it handled in minutes or if in hours.	0
F23	Setting the interval time in relation to the choice of F22	240
F24	Exclusion of valve in short circuit.	0

Warranty

The warranty lasts for 2 years. The manufacturer will replace any faulty electronic component at their own facilities only, unless otherwise authorised by the manufacturer.

Warranty Exclusions

The warranty will be cancelled in case of:

- Signs of unauthorised tampering and repairs.
- Incorrect use of the device not respecting technical data.
- Incorrect electric connections.
- Failure to respect system standards.
- Use not in accordance with EC standards.
- Atmospheric events (lightening, electrostatic discharges, power surges).
- Obstructed pneumatic connections. Damaged pipes.

Problem Solution FAQ

Fault	Possible Cause	Solution
The display does not light up.	Burnt fuse.	Check the protection fuse on the power voltage. Check that the power voltage is present and compliant with that required for the device (terminals 1 and 3).
The outputs are not activated.	Incorrect output voltage. Wiring to solenoid valves.	Check that the unit and solenoid valve output voltage agree. Check wiring between economiser and solenoid valves.
The differential pressure reading is not correct.	Obstructed pneumatic connections. Damaged pipes.	Check that the differential pressure is 0.00 kPa with the pipes disconnected. In this case, check that the connection pipes between device and filter are not obstructed or damaged.
The cleaning cycle is not carried out.	The set cycle start threshold (F08) is too high and therefore the cycle is not activated.	Adjust the start-up pressure threshold or set the economiser to MANUAL mode (F01=0).
Do alarm messages appear?		Check the alarm code with the table.
Do the alarms fail to activate signalling devices?	System wiring errors. No power to alarm devices.	The alarm devices must be powered by voltage external to the economiser. Activating to open the respective relay.
Does post-cleaning start during normal cleaning?	Fan threshold (F12) set too high.	Change the post-cleaning start-up threshold (F12) by lowering it.
Does post-cleaning fail to start when the normal cleaning cycle ends?	Fan threshold (F12) set too low.	Check that the measured pressure is lower than the post-cleaning activation pressure when the fan is off.
Does the economiser occasionally reset?	Check that there is no filtered pulse load on the power line (spot welding machines, welding machines, plasma cutters etc.).	Install a filter on the power line of the economiser, if needed.
The value of 0.0 kPa does not appear on the display when the fan is off.	dP zero calibration (F07) is not correct.	Calibrate the dP zero by appropriately setting the parameter F07 or running the self-calibration function explained on page 10.

Declaration Of Conformity Of The Manufacturer



The Manufacturer:

TURBO SRL

The Manufacturer's Address:

Via Po 33/35 20811 Cesano Maderno (MB), Italy

Declares that

Product Name:

Economiser E2T

Models:

E2T 4 - 16

Product Options:

All

Complies with the following directives:

Directive 2014/30/EU Electromagnetic Compatibility compliant with Harmonised European standards EN61000-6-2:2005 class B of EN61000-6-4:2001

Directive 2014/35/EU Low Voltage compliant with Harmonised European Standards EN 60947-1:2004

A typical configuration of the product was tested.

Cesano Maderno, 01.03.2016

F. MESSINA (C.E.O.)

TURBO s.r.l.

Code And Serial Number